

PORTER CABLE®

**10 IN. (254 MM) FOLDING
COMPOUND MITER SAW**

**SCIE REPLIABLE À ONGLET
COMBINÉ DE 10 PO. (254 MM)**

**SIERRA DE INGLETE COMPUESTA
PLEGADIZA DE 10 PUL. (254 MM)**

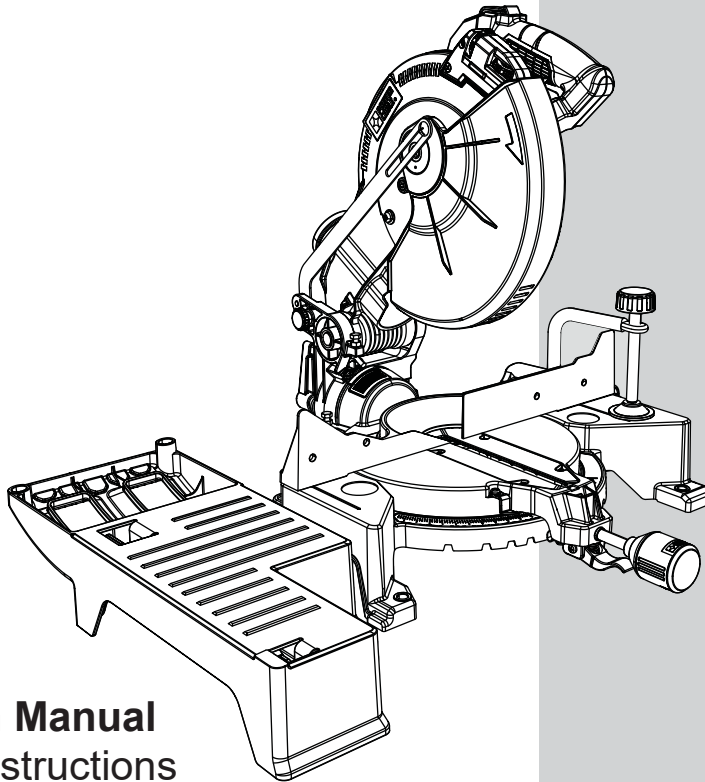

Instruction Manual
Manuel d'instructions
Manual de instrucciones

www.portercable.com

INSTRUCTIVO DE OPERACIÓN,
CENTROS DE SERVICIO Y PÓLIZA
DE GARANTÍA.
⚠ **ADVERTENCIA:** LÉASE ESTE
INSTRUCTIVO ANTES DE USAR EL
PRODUCTO.

**CATALOG NUMBER
PCXB115MS**

TABLE OF CONTENTS

SECTION	PAGE
PRODUCT SPECIFICATIONS.....	2
SAFETY GUIDELINES - DEFINITIONS	3
POWER TOOL SAFETY	4
MITER SAW SAFETY	6
ELECTRICAL REQUIREMENTS AND SAFETY	8
TOOLS NEEDED TO REMOVE OR INSTALL BLADE	10
TOOLS NEEDED TO FOR ADJUSTMENT	10
CARTON CONTENTS	10
UNPACKING YOUR FOLDING MITER SAW	11
KNOW YOUR FOLDING MITER SAW	12
GLOSSARY OF TERMS.....	13
ASSEMBLY AND ADJUSTMENTS	15
OPERATION	25
MAINTENANCE	34
TROUBLESHOOTING GUIDE	36
ACCESSORIES AND ATTACHMENTS	38
PARTS LIST.....	39
WARRANTY.....	44

PRODUCT SPECIFICATIONS

MOTOR

Power Source 120 V AC, 60 Hz,
15 A

Speed (No load) 4500 RPM

Electric Brake Yes

Double Insulated Yes

BLADE

Diameter 10 in. (254 mm)

Arbor 5/8 in. (16 mm)

CUTTING CAPACITY (Dimensional lumber)

Cross Cut 0° x 0° 2 x 6 in.
(50.8 x 152.4 mm)

Miter Cut 45° x 0° 2 x 4 in.
(50.8 x 101.6 mm)

Bevel Cut 0° x 45° 2 x 6 in.
(50.8 x 152.4 mm)

Compound Cut 45° x 45° 2 x 4 in.
(50.8 x 101.6 mm)

Crown Molding Nested 4-1/4 in. (107.9 mm)

ROTATING TABLE

Miter Range 0-48° Left; 0-55° Right

Miter Detent Stops 0°, 15°, 22.5°, 31.6°,
45° (R & L), 55° (R)

Bevel Range 0-47° Left

Bevel Positive Stops 0°, 45° (L)

WARNING

To avoid electrical hazards, fire hazards or damage to the miter saw, use proper circuit protection. This miter saw is wired at the factory for 120 Volt operation. It must be connected to a 120 Volt / 15 Ampere time delay fuse or circuit breaker. To avoid shock or fire, replace power cord immediately if it is worn, cut or damaged in any way. Before using your miter saw, it is critical that you read and understand these safety rules. Failure to follow these rules could result in serious injury to you or damage to the miter saw.

SAFETY GUIDELINES - DEFINITIONS

WARNING ICONS

Your power tool and its Instruction Manual may contain “WARNING ICONS” (a picture symbol intended to alert you to and/or instruct you how to avoid a potentially hazardous condition). Understanding and heeding these symbols will help you operate your tool better and safer. Shown below are some of the symbols you may see.



SAFETY ALERT: Precautions that involve your safety.



PROHIBITION



WEAR EYE PROTECTION: Always wear safety goggles or safety glasses with side shields.



WEAR RESPIRATORY AND HEARING PROTECTION: Always wear respiratory and hearing protection.



READ AND UNDERSTAND INSTRUCTION MANUAL: To reduce the risk of injury, user and all bystanders must read and understand instruction manual before using this product.



KEEP HANDS AWAY FROM THE MOVING PART AND CUTTING SURFACE: Failure to keep your hands away from the moving part and cutting surface will result in serious personal injury.



SUPPORT AND CLAMP WORK



DANGER

DANGER: Indicates an imminently hazardous situation which, if not avoided, will result in death or serious injury.



WARNING

WARNING: Indicates a potentially hazardous situation which, if not avoided, could result in death or serious injury.



CAUTION

CAUTION: Indicates a potentially hazardous situation which, if not avoided, may result in minor or moderate injury.

NOTICE

NOTICE: Used without the safety alert symbol indicates potentially hazardous situation which, if not avoided, may result in property damage.



WARNING

Some dust created by power sanding, sawing, grinding, drilling and other construction activities contains chemicals known to the state of California to cause cancer, birth defects or other reproductive harm. Some examples of these chemicals are:

- Lead from lead-based paints,
- Crystalline silica from bricks and cement and other masonry products, and
- Arsenic and chromium from chemically-treated lumber.

Your risk from these exposures varies, depending on how often you do this type of work. To reduce your exposure to these chemicals: work in a well ventilated area, and work with approved safety equipment, such as those dust masks that are specially designed to filter out microscopic particles. Avoid prolonged contact with dust from power sanding, sawing, grinding, drilling, and other construction activities. Wear protective clothing and wash exposed areas with soap and water. Allowing dust to get into your mouth, eyes, or lay on the skin may promote absorption of harmful chemicals.



WARNING





Use of this tool can generate and/or disperse dust, which may cause serious and permanent respiratory or other injury. Always use NIOSH/OSHA approved respiratory protection appropriate for the dust exposure. Direct particles away from face and body.



POWER TOOL SAFETY

GENERAL SAFETY INSTRUCTIONS BEFORE USING THIS POWER TOOL

Safety is a combination of common sense, staying alert and knowing how to use your power tool.

WARNING

- **To avoid mistakes that could cause serious injury, do not plug the tool in until you have read and understood the following.**
 - **Read all instructions before operating product. Failure to follow all instructions listed below may result in electric shock, fire and/or serious injury.**
1.  **READ** and become familiar with the entire Instruction Manual. **LEARN** the tool's application, limitations and possible hazards.
 2. **KEEP GUARDS IN PLACE** and in working order.
 3. **REMOVE ADJUSTING KEYS AND WRENCHES.** Form the habit of checking to see that keys and adjusting wrenches are removed from the tool before turning ON.
 4. **KEEP WORK AREA CLEAN.** Cluttered areas and benches invite accidents.
 5. **DO NOT USE IN DANGEROUS ENVIRONMENTS.** Do not use power tools in damp or wet locations, or expose them to rain or snow. Keep work area well lit.
 6. **KEEP CHILDREN AWAY.** All visitors and bystanders should be kept a safe distance from work area.
 7. **MAKE WORKSHOP CHILD PROOF** with padlocks, master switches or by removing starter keys.
 8. **DO NOT FORCE THE TOOL.** It will do the job better and safer at the rate for which it was designed.
 9. **USE THE RIGHT TOOL.** Do not force the tool or an attachment to do a job for which it was not designed.
 10. **USE PROPER EXTENSION CORDS.** Make sure your extension cord is in good condition. When using an extension cord, be sure to use one heavy enough to carry the current your product will draw. An undersized cord will result in a drop in line voltage and in loss of power which will cause the tool to overheat. The table on page 9 shows the correct size to use depending on cord length and nameplate ampere rating. If in doubt, use the next heavier gauge. The smaller the gauge number, the heavier the cord.
 11. **WEAR PROPER APPAREL.** Do not wear loose clothing, gloves, neckties, rings, bracelets or other jewelry which may get caught in moving parts. Nonslip footwear is recommended. Wear protective hair covering to contain long hair.
 12.  **ALWAYS WEAR EYE PROTECTION.** Any power tool can throw foreign objects into the eyes and could cause permanent eye damage. **ALWAYS** wear Safety Goggles (not glasses) that comply with ANSI Safety standard Z87.1. Everyday eyeglasses have only impact-resistant lenses. They **ARE NOT** safety glasses. **NOTE:** Glasses or goggles not in compliance with ANSI Z87.1 could seriously injure you when they break.
 13.  **WEAR A FACE MASK OR DUST MASK.** Sawing operation produces dust.
 14.  **SECURE WORK.** Use clamps or a vise to hold work when practical. It is safer than using your hand and it frees both hands to operate the tool.
 15. **DISCONNECT TOOLS FROM POWER SOURCE** before servicing, and when changing accessories such as blades, bits and cutters.

16. **REDUCE THE RISK OF UNINTENTIONAL STARTING.** Make sure switch is in the OFF position before plugging the tool in.
17. **USE RECOMMENDED ACCESSORIES.** Consult this Instruction Manual for recommended accessories. The use of improper accessories may cause risk of injury to yourself or others.
18. **NEVER STAND ON THE TOOL.** Serious injury could occur if the tool is tipped or if the cutting tool is unintentionally contacted.
19. **CHECK FOR DAMAGED PARTS.** Before further use of the tool, a guard or other part that is damaged should be carefully checked to determine that it will operate properly and perform its intended function – check for alignment of moving parts, binding of moving parts, breakage of parts, mounting and any other conditions that may affect its operation. A guard or other part that is damaged should be properly repaired or replaced.
20. **NEVER LEAVE THE TOOL RUNNING UNATTENDED. TURN THE POWER “OFF”.** Do not walk away from a running tool until the blade comes to a complete stop and the tool is unplugged from the power source.
21. **DO NOT OVERREACH.** Keep proper footing and balance at all times.
22. **MAINTAIN TOOLS WITH CARE.** Keep tools sharp and clean for best and safest performance. Follow instructions for lubricating and changing accessories.
23. **DO NOT** use power tool in presence of flammable liquids or gases.
24. **DO NOT** operate the tool if you are under the influence of any drugs, alcohol or medication that could affect your ability to use the tool properly.
25. Dust generated from certain materials can be hazardous to your health. Always operate saw in well-ventilated area and provide for proper dust removal.
26.  **WARNING**
People with electronic devices, such as pacemakers, should consult their physician(s) before using this product. Operation of electrical equipment in close proximity to a heart pacemaker could cause interference or failure of the pacemaker.
27.  **WEAR HEARING PROTECTION** to reduce the risk of induced hearing loss.

MITER SAW SAFETY

SPECIFIC SAFETY INSTRUCTIONS FOR THIS MITER SAW

WARNING

To reduce the risk of injury, you must unplug the saw from power source before folding for transportation or storage.

1. **DO NOT** operate the miter saw until it is completely assembled and installed according to these instructions.
2. **IF YOU ARE NOT** thoroughly familiar with the operation of miter saws, seek guidance from your supervisor, instructor or other qualified person.
3. **ALWAYS** hold the work firmly against the fence and table. **DO NOT** perform any operation free hand (use clamp wherever possible).
4. **KEEP HANDS** out of the path of the saw blade. If the workpiece you are cutting would cause your hands to be within 7-5/16 in. of the saw blade, the workpiece should be clamped in place before making the cut.
5. **BE SURE** the blade is sharp, runs freely and is free of vibration.
6. **ALLOW** the motor to come up to full speed before starting a cut.
7. **KEEP THE MOTOR AIR SLOTS CLEAN** and free of chips or dust.
8. **ALWAYS MAKE SURE** all handles are tight before cutting, even if the table is positioned in one of the positive stops.
9. **BE SURE** both the blade and the collar are clean and the arbor bolt is tightened securely.
10. **USE** only blade collars specified for your saw.
11. **NEVER** use blades larger in diameter than 10 inches.
12. **NEVER** apply lubricants to the blade when it is running.
13. **ALWAYS** check the blade for cracks or damage before operation. Replace a cracked or damaged blade immediately.
14. **NEVER** use blades recommended for operation at less than 4500 RPM.
15. **ALWAYS** keep the blade guards in place and use at all times.
16. **NEVER** reach around the saw blade.
17. **MAKE SURE** the blade is not contacting the workpiece before the switch is turned ON.
18. **IMPORTANT:** After completing the cut, release the trigger and wait for the blade to stop before returning the saw to the raised position.
19. **MAKE SURE** the blade has come to a complete stop before removing or securing the workpiece, changing the workpiece angle or changing the angle of the blade.
20. **NEVER** cut metals or masonry products with this tool. This miter saw is designed for use on wood and wood-like products.
21. **PROVIDE** adequate support to the sides of the saw table for long work pieces.
22. **NEVER** use the miter saw in an area with flammable liquids or gases.
23. **NEVER** use solvents to clean plastic parts. Solvents could possibly dissolve or otherwise damage the material.
24. **SHUT OFF** the power before servicing or adjusting the tool.
25. **DISCONNECT** the saw from the power source and clean the machine when finished using.

26. **MAKE SURE** the work area is clean before leaving the machine.
27. **SHOULD** any part of your miter saw be missing, damaged, or fail in any way, or any electrical component fail to perform properly, remove the plug from the power supply outlet. Replace missing, damaged, or failed parts before resuming operation.
28. Because of the downward cutting motion, your safety requires that you stay very alert to keep hands and fingers away from the path that the blade travels.
29. Be sure all guards are in place and working. If a guard seems slow to return to its normal position or “hangs-up”, stop using at once and have it repaired immediately by a certified and licensed technician. Be alert at all times - especially during repetitive, monotonous operations. Don’t be lulled into carelessness due to a false sense of security. Clean the lower guard frequently to help visibility and movement. Unplug before adjustment or cleaning.
30. Abrasive cut-off wheels should not be used on miter saws. Miter saw guards are not appropriate for abrasive cut-off wheels.
31. To avoid loss of control or placing hands in the path of the blade, hold or clamp all material securely against the fence when cutting. Do not perform operations freehand.
32. Support long material at the same height as the saw table.
33. After completing a cut, release the trigger switch and allow the blade to come to a complete stop, then raise the saw blade from the workpiece.
34. Lock the miter saw head in the down position when not in use.
35. **DRY RUN** - It is important to know where the blade will intersect with the workpiece during cutting operations. Always perform a simulated cutting sequence with the power tool switched OFF to gain an understanding of the projected path of the saw blade.
36. **DO NOT USE THIN KERF BLADES** they can deflect and contact guard and can cause possible injury to the operator.
37. **⚠ WARNING**
DO NOT STORE MATERIALS ON TOP OF SAW when in the folded or unfolded position.
38. **DO NOT USE** this saw to cut tree limbs or logs.

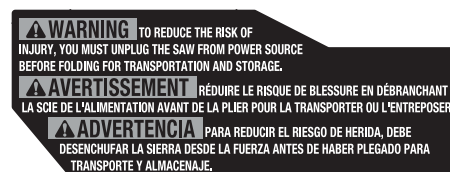

ELECTRICAL REQUIREMENTS AND SAFETY

POWER SUPPLY AND MOTOR SPECIFICATIONS

The AC motor used in this saw is a universal, nonreversible type. See "MOTOR" in the "PRODUCT SPECIFICATIONS" section on page 2.

⚠ WARNING

To avoid electrical hazards, fire hazards, or damage to the tool, use proper circuit protection. Your saw is wired at the factory for 120 V operation. Connect to a 120 V, 15 A circuit and use a 15 A time delay fuse or circuit breaker. To avoid shock or fire, if power cord is worn or cut, or damaged in any way, have it replaced immediately.

ELECTRICAL REQUIREMENTS

Replacement parts – When servicing use only identical replacement parts.

Polarized plugs – This saw has a plug that looks like the one shown below:

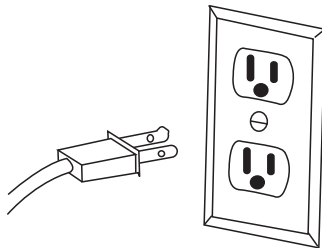

To reduce the risk of electrical shock, this saw has a polarized plug (one blade is wider than the other). This plug will fit in a polarized outlet only one way. If the plug does not fit fully in the outlet, reverse the plug. If it still does not fit, contact a qualified electrician to install the proper outlet. Do not change the plug in any way.

⚠ WARNING

Double insulation does not take the place of normal safety precautions when operating this tool.

To avoid electrocution:

1. Use only identical replacement parts when servicing a tool with double insulation. Servicing should be performed by a qualified technician.

2. Do not use power tools in wet or damp locations or expose them to rain or snow.

MOTOR SAFETY PROTECTION IMPORTANT:

To avoid motor damage, the motor should be blown out or vacuumed frequently to keep sawdust from interfering with the motor ventilation.

1. **CONNECT** this saw to a 120 V, 15 A circuit with a 15 A time-delay fuse or circuit breaker. Using the wrong size fuse can damage the motor.
2. If the motor won't start, release the trigger switch immediately. **UNPLUG THE SAW.** Check the saw blade to make sure it turns freely. If the blade is free, try to start the saw again. If the motor still does not start, refer to the **TROUBLESHOOTING GUIDE.**
3. If the tool suddenly stalls while cutting wood, release the trigger switch, unplug the tool, and free the blade from the wood. The saw may now be started and the cut finished.
4. **FUSES** may "blow" or circuit breakers may trip frequently if:
 - a. **MOTOR** is overloaded – overloading can occur if you feed too rapidly or make too many start/stops in a short time.
 - b. **LINE VOLTAGE** is more than 10% above or below the nameplate voltage rating. For heavy loads, the voltage at motor terminals must equal the voltage specified on the nameplate.
 - c. **IMPROPER** or dull saw blades are used.
5. Most motor troubles may be traced to loose or incorrect connections, overload, low voltage or inadequate power supply wiring. Always check the connections, the load and supply circuit if the motor doesn't run well. Check minimum gauge for the length of cord you are using on the chart below.

GUIDELINES FOR EXTENSION CORDS

Use a proper extension cord. Make sure your extension cord is in good condition. When using an extension cord, be sure to use one heavy enough to carry the current your product will draw. An undersized cord will cause a drop in line voltage, resulting in loss of power and cause overheating. The table below shows the correct size to use depending on cord length and nameplate ampere rating. If in doubt, use the next heavier gauge. The smaller the gauge number, the heavier the cord.

Be sure your extension cord is properly wired and in good condition. Always replace a damaged extension cord or have it repaired by a qualified person before using it. Protect your extension cords from sharp objects, excessive heat and damp or wet areas.

Use a separate electrical circuit for your tools. This circuit must not be less than a #12 wire with a 16 A time-lag fuse or a #14 wire with a 12 A time-lag fuse. **NOTE:** When using an extension cord on a circuit with a #14 wire, the extension cord must not exceed 25 feet in length. Before connecting the tool to the power line, make sure the switch is in the OFF position and the electric current is rated the same as the current stamped on the motor nameplate, running at a lower voltage will damage the motor.

MINIMUM GAUGE FOR EXTENSION CORDS (AWG)					
(When using 120 volts only)					
Ampere Rating		Total length of Cord			
More Than	Not More Than	25ft.	50ft.	100ft.	150ft.
0	6	18	16	16	14
6	10	18	16	14	12
10	12	16	16	14	12
12	16	14	12	Not Recommended	

WARNING

In all cases make certain the receptacle in question is properly grounded. If you are not sure, have a certified electrician check the receptacle.

TOOLS NEEDED TO REMOVE OR INSTALL BLADE

Supplied



Blade Wrench

TOOLS NEEDED FOR ADJUSTMENT

Not Supplied

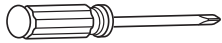

Phillips Screwdriver

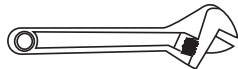

Adjustable Wrench

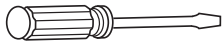

Slotted Screwdriver

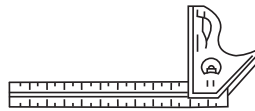

Combination Square

COMBINATION SQUARE MUST BE TRUE

Should not gap or overlap when square is flipped over (see dotted figure).

Draw light line on Straight edge or a 3/4 in. board along this board, this edge must be perfectly straight.

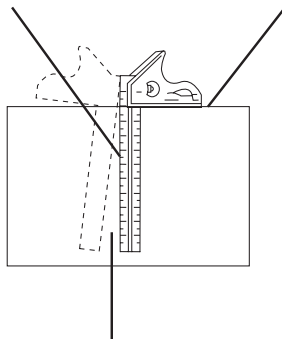

Should not gap or overlap when square is flipped over (see dotted figure).

CARTON CONTENTS

UNPACKING AND CHECKING CONTENTS

Carefully unpack the miter saw and all its parts, and compare against the list below and the illustration on the next page. With the help of an assistant place the saw on a secure surface and examine it carefully.

⚠ WARNING

- To avoid injury from unexpected starting or electrical shock, do not plug the power cord into a source of power during unpacking and assembly. The cord must remain unplugged whenever you are adjusting/assembling the miter saw.
- The miter saw is heavy and should be lifted with care. If needed, get the assistance of someone to lift and move the miter saw.
- If any part is missing or damaged, do not attempt to assemble the miter saw, or plug in the power cord until the missing or damaged part is correctly replaced.

TABLE OF LOOSE PARTS

ITEM	DESCRIPTION	Q'TY
A.	Miter saw	1
B.	Instruction manual	1
C.	Blade wrench	1
D.	Hold-down clamp	1
E.	Miter handle	1
F.	Dust bag	1
G.	Support base	1

UNPACKING YOUR FOLDING MITER SAW

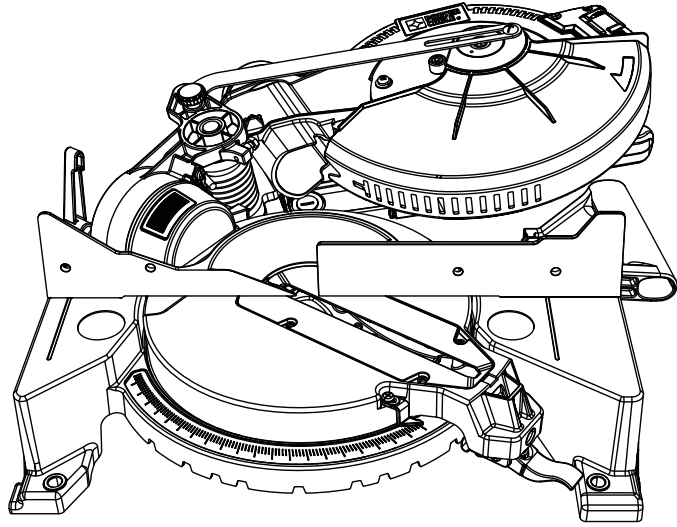

A

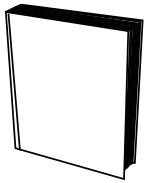

B



C

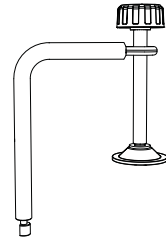

D

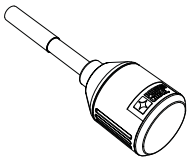

E

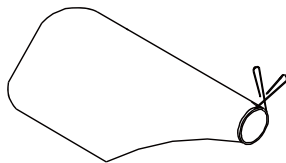

F

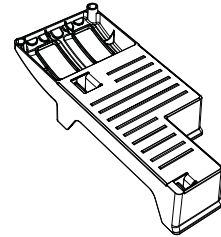

G

KNOW YOUR FOLDING MITER SAW

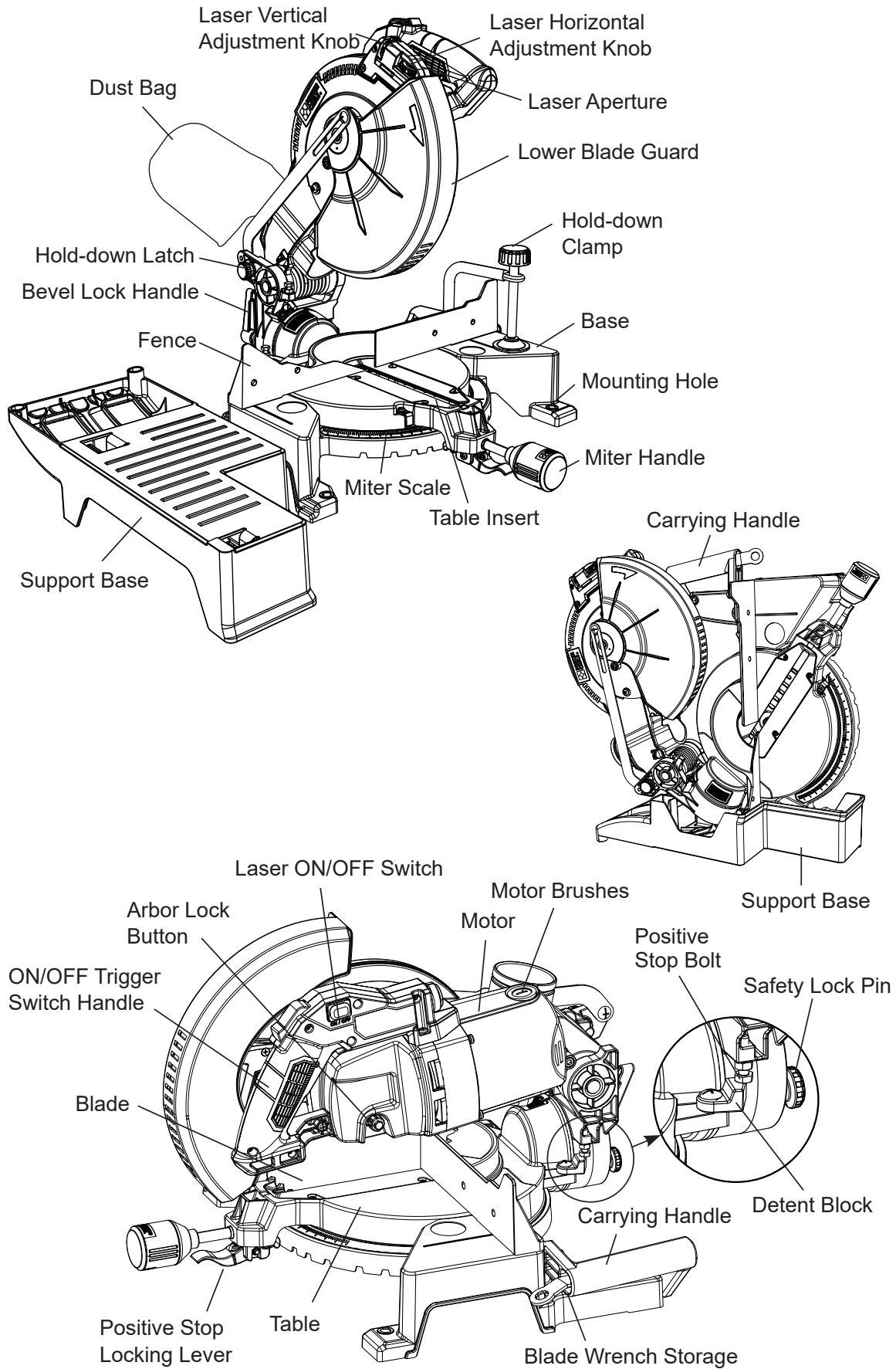

GLOSSARY OF TERMS

AMPERAGE (AMPS) – A measure of the flow of electric current. Higher ratings generally means the tool is suited for heavier use.

ARBOR LOCK – Allows the user to keep the blade from rotating while tightening or loosening the arbor bolt during blade replacement or removal.

BASE – Supports the table, holds accessories and allows for workbench or leg set mounting.

BEVEL LOCK HANDLE – Locks the miter saw at a desired bevel angle.

BEVEL SCALE – To measure the bevel angle of the saw blade.

CARBIDE TIPPED – Extremely hard steel pieces with sharp cutting edges fastened to cutting tools such as saw blades.

COVER PLATE SCREW – Loosen this screw and rotate the plate for access to the blade arbor bolt.

EXTENSION CORD – An electric cord used between power tools and outlets to extend the range of the tools. The more amperage your tool uses, the longer the distance, the larger the size of the wire needed in your extension cord.

EYE PROTECTION – Goggles or spectacles intended to protect your eyes. Eye protection should meet the requirements of ANSI Z.87.1 (USA) or CSA Z94.3-M88 (Canada).

FACE SHIELD – An impact resistant shield that helps to protect your face from chips, sparks, small debris. Should only be used in conjunction with additional eye protection.

FENCE – Helps to keep the workpiece from moving when sawing.

GUARD – Protective device that forms a barrier between a hazardous object such as a blade, wheel or cutter and the operator.

HOLD-DOWN LATCH – Locks the miter saw in the lowered position for compact storage and transportation.

INSTRUCTION OR OPERATOR'S MANUAL – Booklet accompanying your power tool that describes the hazards and safe operation procedures, outlines basic tool operation, care and maintenance.

MITER HANDLE – Used to rotate the table, and to rotate the saw to a right or left cutting position.

MITER SCALE – Measures the miter angle of the saw blade. Positive stop index points have been provided at 0°, 15°, 22.5°, 31.6°, 45° right & left and 55° right.

MOUNTING HOLES – To mount the miter saw to a stable surface.

ON/OFF TRIGGER SWITCH – To start the tool, squeeze the trigger. Release the trigger to turn off the miter saw.

POSITIVE STOP LOCKING LEVER – Locks the miter saw at a preset positive stop for the desired miter angle.

SWITCH HANDLE – The switch handle contains the trigger switch and the laser on/off switch. The blade is lowered into the workpiece by pushing down on the handle. The saw will return to its upright position when the handle is released.

WARNING LABELS – Read and understand for your own safety. Make sure all labels are present on machine and legible.

BLADE WRENCH STORAGE – Convenient storage to prevent misplacing the blade wrench.

WOODWORKING TERMS

ARBOR – The shaft on which a blade is mounted.

BEVEL CUT – An angle cut made through the face of the workpiece.

COMPOUND CUT – An angled cut to both the edge and face of a board, most common use is with crown molding.

CROSS CUT – A cut which runs across the board perpendicular to the grain.

FREEHAND – Performing a cut without using a fence (guide), hold down or other proper device to prevent the workpiece from twisting during the cutting operation.

HEEL – Misalignment of the blade.

KERF – The width of a saw cut, determined by the thickness and set of the blade.

KICKBACK – sudden and unintended movement of the tool or workpiece. It is typically caused by binding or pinching of the workpiece.

MITER CUT – A miter is a type of joint where the two parts to be joined are cut at an angle, and typically the finished joint forms a 90-degree angle. Also commonly spelled “mitre”.

REVOLUTIONS PER MINUTE (RPM) – The number of turns completed by a spinning object in one minute.

SAW BLADE PATH – The area of the workpiece or table top directly in line with the travel of the blade or the part of the workpiece which will be cut.

SET – The distance between two saw blade tips, bent outward in opposite directions to each other. The further apart the tips are, the greater the set.

THIN-KERF BLADE – Thinner than normal blades, remove less material, smaller kerfs (between 0.065 in. and 0.070 in.). Blade thinness also may increase the heat generated while cutting.

WORKPIECE – The wood being cut. The surfaces of a workpiece are commonly referred to as faces, ends and edges.

ASSEMBLY AND ADJUSTMENTS

⚠ WARNING To reduce the risk of injury, turn unit off and disconnect it from power source before installing and removing accessories, before adjusting or when making repairs. An accidental start-up can cause injury.

Estimated Assembly Time: 10 - 25 Minutes.

ASSEMBLY INSTRUCTIONS TO RAISE THE CUTTER HEAD (FIG. A, B, C, D, E, F)

⚠ WARNING

To avoid injury, make sure all parts are assembled and adjusted properly before plugging the miter saw into a power outlet and turning it ON.

Fig. A

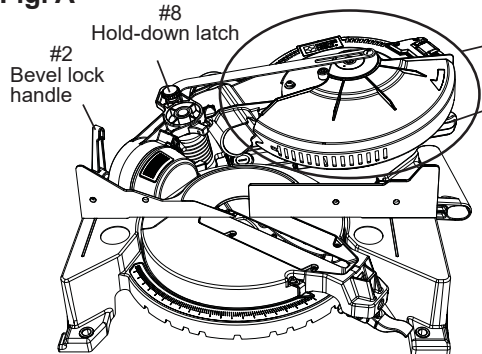
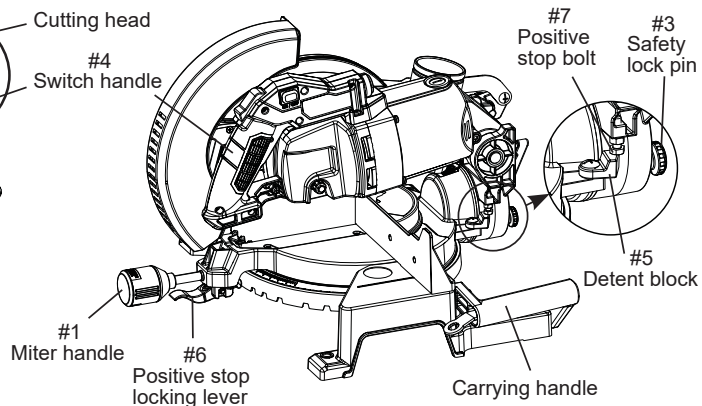

Fig. B



PLACE THE SAW ON A FLAT, STABLE SURFACE.

NOTE: Cut the two tie cables to release the cutter head from the base.

- STEP 1:** Thread the miter handle (1) into the hole located at the front of the table as shown in Figs. B & C.
- STEP 2:** Loosen the bevel lock handle (2) located behind the base as shown in Figs. A & D.
- STEP 3:** Pull out the safety lock pin (3) located next to the bevel lock handle as shown in Fig. D.
- STEP 4:** Lift the cutting head by the switch handle (4) (Fig B) to raise the cutting head straight up just pass the 90° bevel setting.
- STEP 5:** Rotate the metal detent block (5), located on the right side behind the table (Figs. B & E), counterclockwise 180°.
- STEP 6:** Tilt the cutting head back to 90° and then tighten the bevel lock handle (2). The positive stop bolt (7) (Fig E) will now rest on the detent block (5).
- STEP 7:** Loosen the miter handle (1), grasp it and lift up the positive stop locking lever (6) (Figs. B & C) located under the miter handle, to turn the table to 0° as shown on the miter scale. Retighten the miter handle (1).
- STEP 8:** Slightly push down the cutting head using the switch handle (4) and pull out the hold-down latch (8) (Fig F) located near the back on the left side of saw. This releases the cutting head.

Fig. C

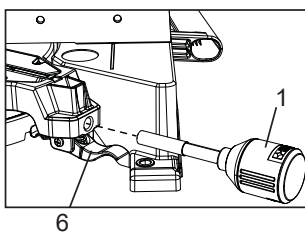

Fig. D

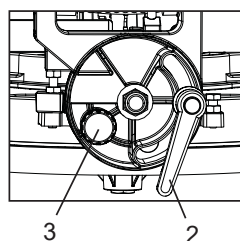

Fig. E

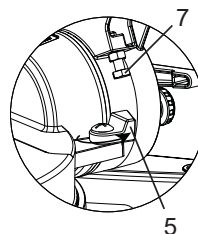
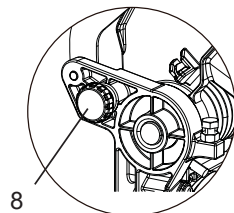

Fig. F



LOCKING THE CUTTING HEAD (FIG. A, F)

When not in use, the miter saw cutting head should always be locked in the down position.

1. Pull down the switch handle (4) to place the cutting head in its lowest position.
2. Push the hold-down latch (8) in.

IMPORTANT: To avoid damage, never carry the miter saw by the switch handle, the cutting head or the miter handle. ALWAYS use the designated carrying handle. (See Figs. B & M)

⚠ WARNING

- To reduce the risk of injury, you must unplug the saw from power source before folding for transportation or storage.
- To reduce the risk of injury, turn unit off and disconnect it from power source before installing and removing accessories, before adjusting or when making repairs. An accidental start-up can cause injury.
- Make sure blade has stopped rotating before folding the saw.

FOLDING THE CUTTING HEAD FOR TRANSPORTATION AND STORAGE (FIG. A, B)

1. Keep the cutting head in the up position.
2. Slightly push down the switch handle (4) and push the hold-down latch (8) into the locking hole. (Fig. A)
3. Loosen the miter handle (1), grasp it and lift up the positive stop locking lever (6) to turn the turntable to the right 55° and then tighten the miter handle. (Fig. B)
4. Loosen the bevel lock handle (2), tilt the cutting head towards left over 90° and then turn the detent block (5) clockwise 180° to release the positive stop bolt (7). (Fig. B)
5. Pull out the safety lock pin (3) and grasp the switch handle (4) to lower the cutting head towards the right and down until hearing a "click" sound. (Fig. B)
NOTE: Make sure the cutting head is locked in position and could not be moved.
6. Tighten the bevel lock handle (2). (Fig. A)

⚠ WARNING

DO NOT STORE MATERIALS ON TOP OF SAW when in the folded or unfolded position.

INSTALLING THE DUST BAG (FIG. G)

1. Squeeze the metal collar wings (1) of the dust bag (2).
2. Place the dust bag neck opening around the dust port (3), and release the metal collar wings (1).

⚠ WARNING

Do not use this saw to cut and/or sand metals. The hot chips or sparks may ignite sawdust from the bag material.

Fig. G

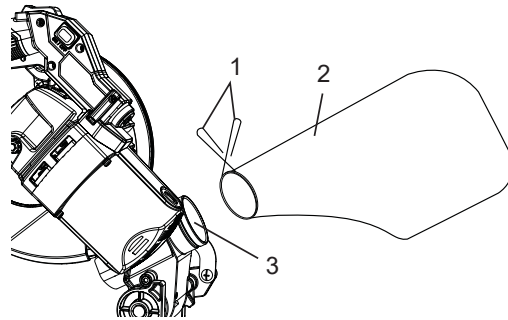

INSTALLING THE HOLD-DOWN CLAMP ASSEMBLY (FIG. H, H-1)

⚠ WARNING

CUTTING SMALL OR ROUND MATERIAL It should be cut just like wood and **CLAMPED OR HELD FIRMLY TO THE FENCE TO KEEP IT FROM ROLLING.** This is extremely important when making angle cuts.

1. Place the hold-down clamp assembly (1) into the mounting hole (2) located behind the fence. The clamp should be facing toward the back of the miter saw as shown in Fig. H.
2. The groove on the clamp rod should be fully inserted into the mounting hole of the base without being visible. If the groove is visible, the clamp will not be secure.
3. Rotate the hold-down clamp assembly (1) 180 degrees toward the front of the miter saw.
4. Loosen the knob (3) to adjust the clamp up or down to firmly clamp the workpiece.
5. The hold-down clamp assembly (1) can be inserted in one of the two mounting holes (2) located behind the fence on either side of the base. (Fig. H-1)

NOTE: Place the clamp on the opposite side of the base when bevelling. ALWAYS MAKE DRY RUNS (UNPOWERED) BEFORE FINISH CUTS TO CHECK THE PATH OF THE BLADE. ENSURE THE CLAMP DOES NOT INTERFERE WITH THE ACTION OF THE SAW OR GUARDS.

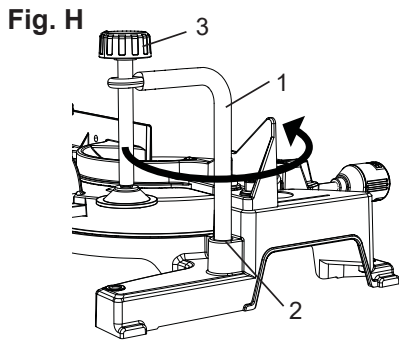
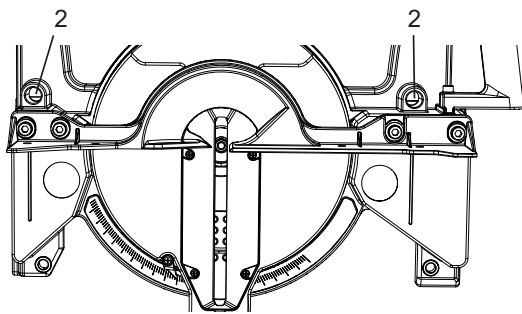

Fig. H-1



SAW BLADE

NOTE: The miter saw comes with the saw blade already installed.

⚠ WARNING

Make sure the blade is installed correctly and is tight before operating. See page 19 in adjustments to tighten or remove the saw blade if necessary.

SAW BLADE WRENCH STORAGE (FIG. I)

For convenient storage and prevention of loss, there is a slot (1) in the carrying handle for storing the blade wrench (2) when not in use.

Fig. I

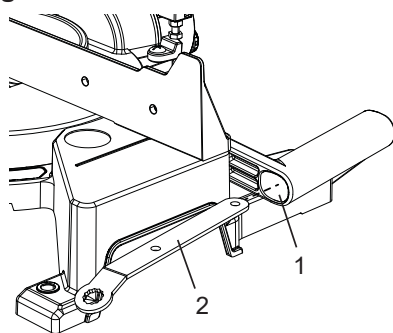

MOUNTING THE MITER SAW (FIG. J, K)

⚠ WARNING

To avoid injury from unexpected saw movement:

- **Before moving the miter saw, disconnect the power cord from the outlet, and lock the cutting arm in the lower position using the hold-down latch.**

NOTE: The hold-down latch is for carrying or storing the tool. It is not to be used for holding the saw while cutting. Lower the cutting head and press in hold-down latch to secure the cutting head.

- **Never carry the miter saw by the power cord or by the trigger switch handle. Carrying the tool by the power cord could cause damage to the insulation or wire connections and result in electric shock or fire.**
- **To avoid injury from flying debris, do not allow visitors to stand behind the saw.**
- **Place the saw on a firm, level workbench where there is room for handling and properly supporting the workpiece.**
- **Support the saw on a level work surface.**
- **Bolt or clamp the saw to its support.**

Mounting instructions:

1. **For stationary use**, place the saw in the desired location, directly on a workbench where there is room for handling and proper support of the workpiece. The base of the saw has four 3/8 in. mounting holes. Select the proper mounting holes based on the size of bolts used. Bolt the base of the miter saw (1) to the workbench (5), using the fastening method as shown in Fig. J.

Fig. J

1. Miter saw base
2. Hex head bolt
3. Rubber washer
4. Flat washer
5. Workbench
6. Flat washer
7. Lockwasher
8. Hex nut
9. Jam nut

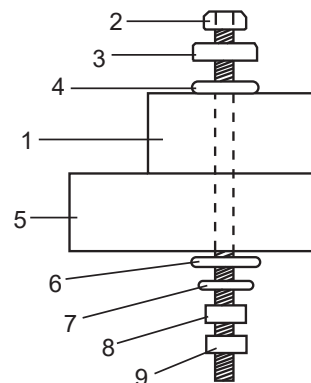

NOTE: Mounting hardware is not included with this tool. Bolts, nuts, washers, and screws must be purchased separately.

2. **For portable use**, place the saw on a 3/4 in. thick piece of plywood. Bolt the base of the miter saw securely to the plywood using the mounting holes on the base. Use C-clamps to clamp this mounting board to a stable work surface at the worksite. (Fig. K)

Fig. K

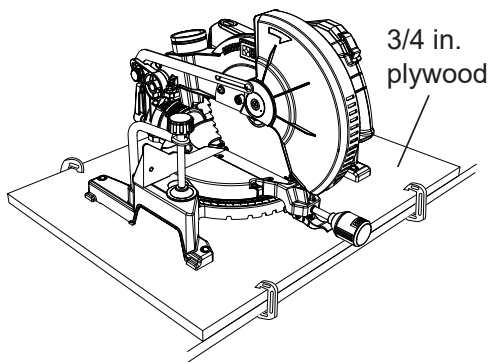

NOTE: If a miter saw stand is used, please follow all instructions shown in that product's instructions for proper mounting.

USING THE SUPPORT BASE (FIG. L, L-1)

1. Fold the miter saw. (See the section of "FOLDING THE CUTTING HEAD FOR TRANSPORTATION AND STORAGE" on page 16.)
2. Place the support base (1) on a flat surface or ground as shown in Fig. L.
3. Align the feet (2) of the base with the grooves (3) of the support base (1) and then insert the folded saw into the support base (1), so that the miter saw could stand on the ground.

⚠ WARNING

To avoid the bevel lock handle (4) interfering with the support base (1) when the folded miter saw is inserted into the support base, pull the bevel lock handle to adjust the direction, and the range of the direction is as shown in Fig. L-1.

Fig. L

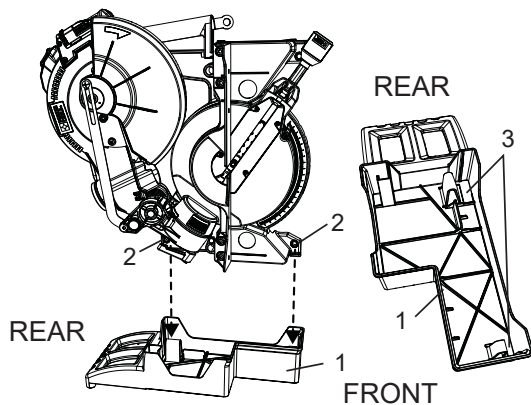
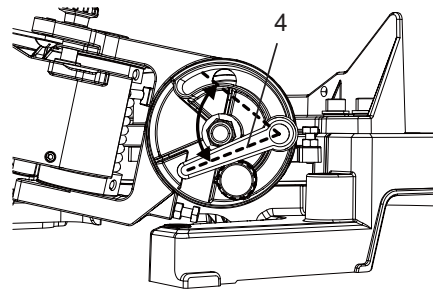

Fig. L-1



View from rear of machine

TRANSPORTING THE SAW (FIG. M)

⚠ WARNING

To reduce the risk of serious personal injury, ALWAYS lock the miter lock handle, bevel lock handle, lock down pin before transporting saw.

NOTE: To avoid damage, never carry the miter saw by the switch handle. To reduce the risk of serious personal injury, ALWAYS secure all clamps, knobs, latches and locks before lifting the saw.

1. Never carry the saw by the switch handle, miter clamp or cutting head. The carry handle is appropriate for when the saw is folded only. When saw is not folded, the hand holds should be used.
2. ALWAYS use the support base when storing the saw vertically.

Fig. M

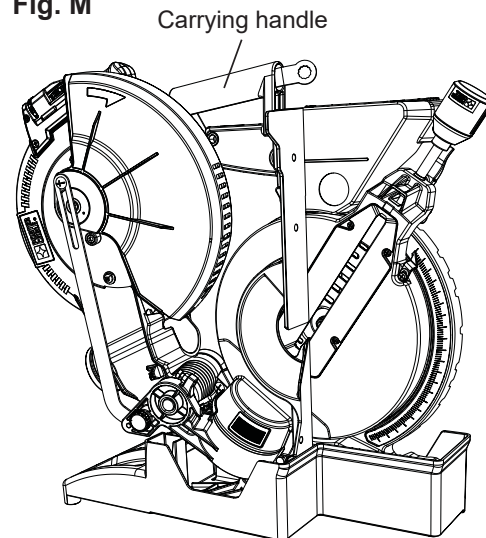

ADJUSTMENT INSTRUCTIONS

REMOVING AND INSTALLING THE BLADE

⚠ WARNING

- Only use 10 inch diameter crosscut blades on this saw. Do not use blades with deep gullets. These can deflect and contact the guard, and can cause damage to the machine and/or serious injury. To avoid injury from an accidental start, make sure the switch is in the OFF position and the plug is not connected to the power source outlet.

NOTE: The miter saw comes with the saw blade already installed.

- Make sure the blade is installed correctly and is tight before operating.

Removing the Blade (Fig. N, O, P)

1. Unplug the saw from the outlet.
2. Raise the cutting head to the upright position.
3. Raise the lower blade guard (1) to the uppermost position. (Fig. N)
4. Loosen the cover plate screw (2) with a Phillips screwdriver.
5. Rotate the cover plate (3) back to expose the arbor bolt (4).
6. Place the provided blade wrench over the arbor bolt (4).

Fig. N

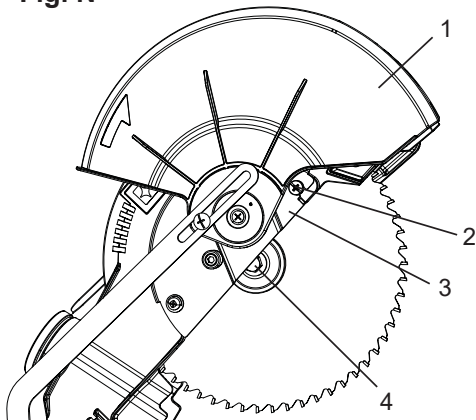

7. Locate the arbor lock button (5) below the trigger switch handle. (Fig. O)
8. Press the arbor lock button (5), holding it in firmly while turning the blade wrench clockwise. This will engage the arbor lock allowing the arbor bolt to be loosened with the blade wrench. Continue to hold the arbor lock button (5) while turning the wrench clockwise to loosen the arbor bolt.

Fig. O

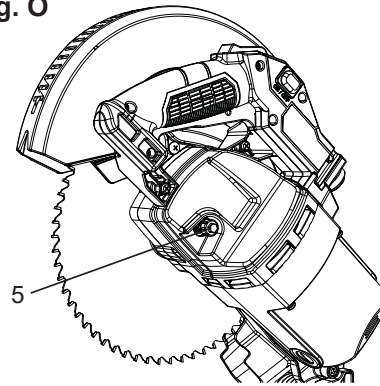

9. Remove the arbor bolt (4), the outer blade collar (6), and the blade (7). (Fig. P)

⚠ CAUTION

Do not remove the inner blade collar (8).

NOTE: Pay attention to the pieces removed, noting their position and direction they face. Wipe the blade collars clean of any sawdust before installing a new blade.

Fig. P

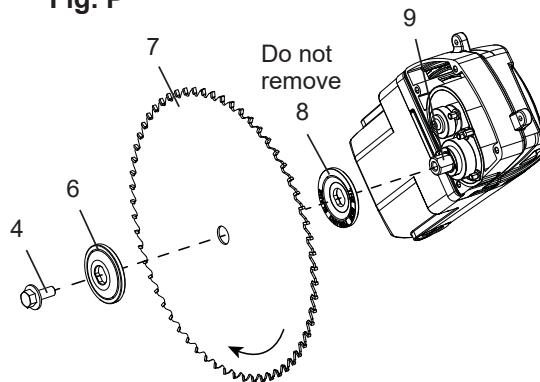

Installing the Blade (Fig. N, O, P)

⚠ WARNING

Un-plug the miter saw before changing/ installing the blade.

1. Install a 10 in. blade with a 5/8 in. arbor hole, making sure the rotation arrow on the blade matches the clockwise rotation arrow on the upper guard, and the blade teeth are pointing downward at the front of the saw.
2. Place the blade (7) onto the arbor (9) and against the inner blade collar (8). Then, place the outer blade collar (6) and thread the arbor bolt (4) counterclockwise onto the arbor. (Fig. P)

IMPORTANT: The flat side of the blade collars must be placed against the blade. Do not install the collars with the curved side against the blade.

3. Place the blade wrench on the arbor bolt (4).

4. Press the arbor lock button (5), holding it in firmly while turning the blade wrench counterclockwise. Continue to press it in while tightening the arbor bolt securely. (Fig. O)
5. Rotate the cover plate (3) back to its original position and tighten the cover plate screw (2) with a Phillips screwdriver. (Fig. N)
6. Lower the blade guard (1) back to its original position.
7. Pull the switch handle down and up several times to confirm the lower blade guard operates without binding.
8. Be sure the arbor lock button (5) is released so the blade turns freely. (Fig. O)

⚠ WARNING

- To avoid injury, never use the saw without the cover plate secure in place. It keeps the arbor bolt from falling out if it accidentally loosens, and helps prevent the spinning blade from coming off the saw.
- If the cover plate is not secure in its proper place, the guard may contact the spinning saw blade, resulting in damage to the saw and severe personal injury.
- Make sure the collars are clean and properly arranged. Lower the blade into the table and check for any contact with the metal base or the saw table.
- **ALWAYS MAKE DRY RUNS (UNPOWERED) BEFORE FINISH CUTS SO THAT YOU CAN CHECK THE PATH OF THE BLADE AND THE OPERATION OF THE GUARDS. DO NOT CROSS HANDS.**

REMOVING AND INSTALLING THE TABLE INSERT (FIG. Q)

⚠ WARNING

To avoid injury:

- Always unplug the saw to avoid accidental starting. Remove all small pieces of material from the table cavity before performing any cuts. The table insert may be removed for this purpose, but always reattach the table insert prior to performing a cutting operation.
- Do not start the miter saw without checking for interference between the blade and table insert. Damage could result to the blade, table insert or turntable if blade strike occurs during the cutting operation.

1. To remove, loosen and remove the four screws (1) on the table inserts (2) with a Phillips screwdriver and remove the table inserts.
2. To install, reposition the table inserts, install the four screws and tighten.

FIG. Q

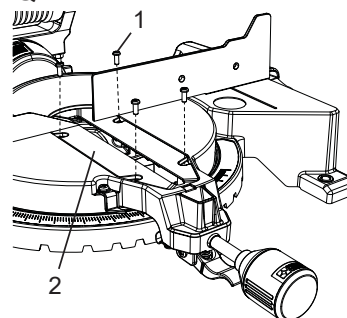

BEVEL STOP ADJUSTMENT

⚠ WARNING

To avoid injury from an accidental start, make sure the switch is in the OFF position and the plug is not connected to the power source outlet.

90° (0°) Bevel Adjustment (Fig. R, S)

1. Loosen bevel lock handle (1) and tilt the cutting arm completely to the right. Tighten the bevel lock handle (1). **NOTE:** Make sure the detent block (2) touches the bevel angle adjustment bolt (3). (Fig. R)
2. Place a combination square (4) on the miter table (5) with the ruler against the table and heel of the square against the saw blade. (Fig. S)
3. If the blade is not 90° square with the miter table, loosen the bevel lock handle (1), tilt the cutting head to the left, loosen the lock nut (6) and turn the bevel angle adjustment bolt (3) in or out with an adjustable wrench until the blade is square with the table. Once alignment is achieved, tighten the lock nut (6) to secure the bolt (3). (Fig. R)
4. Tighten the bevel lock handle (1) after alignment is achieved.

Fig. R

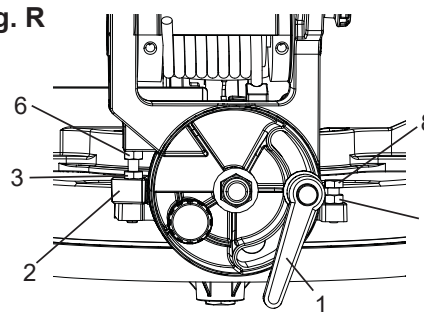

View from rear of machine

Fig. S

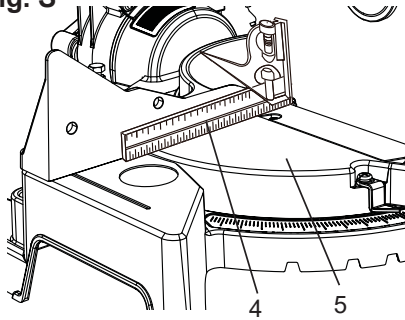

⚠ WARNING

To avoid injury from an accidental start, make sure the switch is in the OFF position and the plug is not connected to the power source outlet.

90° Bevel Pointer Adjustment (Fig. T)

1. When the blade is exactly 90° (0°) to the table, loosen the bevel indicator screw (1) using a Phillips screwdriver.
2. Adjust bevel pointer (2) to the "0" mark on the bevel scale and retighten the screw (1).

Fig. T

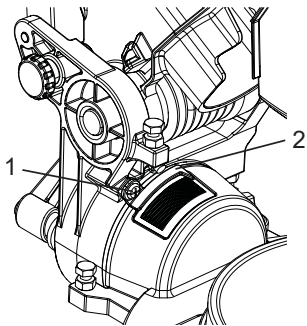

⚠ WARNING

To avoid injury from an accidental start, make sure the switch is in the OFF position and the plug is not connected to the power source outlet.

45° Bevel Stop Adjustment (Fig. R)

1. Set the miter angle to zero degree.
2. Loosen the bevel lock handle (1) and tilt the cutting arm completely to the left.
3. Using a combination square, check to see if the blade is 45° to the table.
4. If the blade is not at 45° to the miter table, tilt the cutting arm to zero degree, loosen the lock nut (7) and turn the bolt (8) in or out accordingly with an adjustable wrench.
5. Tilt the cutting arm back to the left and recheck alignment.

6. Repeat above steps until the blade is 45° to the table. Once alignment is achieved, tighten the lock nut (7) to secure the bolt (8).

MITER SCALE (FIG. U)

The miter saw scale can be easily read, showing miter angles from 0° to 48° to the left, and 0° to 55° to the right. The miter saw table has positive stops at most common angle settings at 0°, 15°, 22.5°, 31.6°, 45° right & left, and 55° right. These positive stops position the blade at the desired angle quickly and accurately. Follow the process below for quickest and most accurate adjustments.

Miter Angles Adjustment:

1. Unlock the table by turning the miter handle (1) counterclockwise.
2. Move the turntable while lifting up on the positive stop lock lever (2) to align the miter scale pointer (3) to the desired degree measurement.
3. If the desired angle is one of the ten positive stops, release the positive stop lock lever (2), making sure the lever snaps into position, and then secure by tightening the miter handle (1).
4. If the miter angle desired is not one of the ten positive stops, simply lock the miter table into desired angle position by turning the miter handle (1) in the clockwise direction.

Miter Angle Pointer Adjustment:

1. Move the table to the 0° positive stop.
2. Loosen the screw (4) that holds the pointer (3) with a Phillips screwdriver.
3. Adjust the pointer (3) to the 0° mark and retighten the screw.

Fig. U

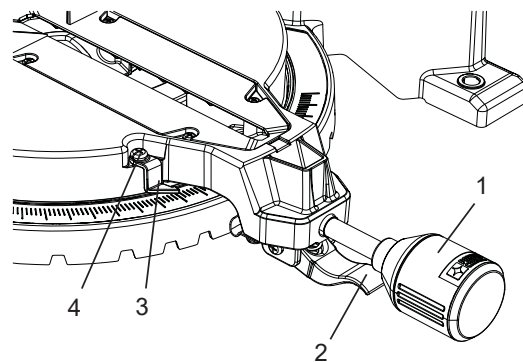

ADJUSTING FENCE SQUARENESS (FIG. V)

1. Loosen the four fence locking bolts (1).
 2. Lower the cutting arm and lock in position.
 3. Using a square (3), lay the heel of the square against the blade and the ruler against the fence (2) as shown.
 4. Adjust the fence 90° to the blade and tighten the four fence locking bolts (1).
- NOTE:** If the saw has not been used recently, recheck blade squareness to the fence and readjust if needed.
5. After fence has been aligned, using a scrap piece of wood, make a cut at 90° then check squareness on the piece. Readjust if necessary.

Fig. V

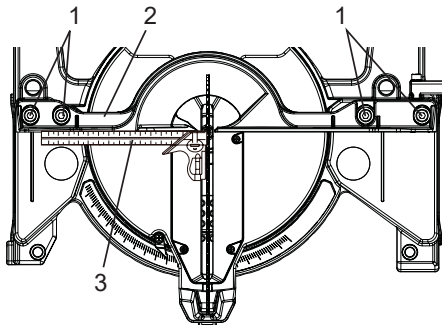

CUTTING HEAD DOWNWARD TRAVEL ADJUSTMENT (FIG. W)

Before each cutting operation, check the position of the blade to make sure it does not contact any metal surface. If it contacts any metal surface, the depth of movement must be adjusted.

⚠ WARNING

To avoid injury from unexpected starting or electrical shock, make sure the trigger switch is disengaged and remove the power cord from the power source.

1. Lower the blade as far as possible.
2. Loosen lock nut (1) using an adjustable wrench.
3. Turn the adjustment bolt (2) out (counterclockwise) to decrease the cutting depth or in (clockwise) to increase the cutting depth.
4. Rotate the blade by hand to check that it does not contact any metal.
5. Repeat steps until adjusted properly, and tighten the lock nut (1) to secure the adjustment bolt (2) into position.

Fig. W

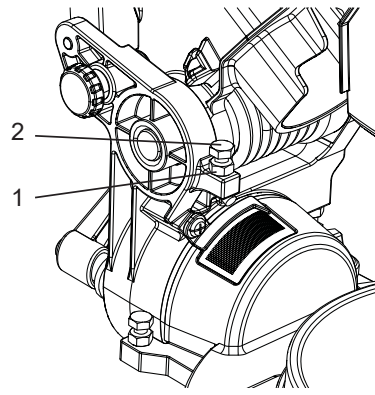

TURNING LASER GUIDE ON (FIG. X)

1. To turn laser on, press on/off rocker switch (1) to "ON" position.
2. To turn laser off, press on/off rocker switch to "OFF" position.

Fig. X

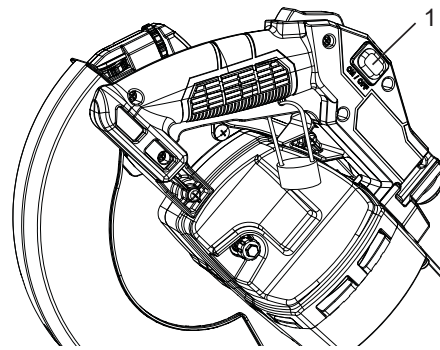

ALIGNING THE LASER GUIDE

The laser line must always be correctly aligned with the blade to ensure straight, even cutting. The laser line will enable you to preview the saw blade path on the stock to be cut before starting the miter saw. This laser guide is powered by the transformed alternating current supply directly through the power lead. **The saw must be connected to the power source and the laser on/off switch must be turned on for the laser line to show.**

⚠ WARNING

- **To prevent serious injury, insert a padlock (not provided) or chain with padlock through the hole in the ON/OFF Trigger Switch prior to making any laser adjustment.**

- Do not remove the lock from the ON/OFF Trigger Switch during any laser adjustment.

AVOID DIRECT EYE CONTACT WITH LASER (FIG. X, Y)

⚠ WARNING

- A laser line radiates from the laser aperture when the laser guide is turned on. Avoid direct eye contact. (Fig. X)
- Laser Warning Label:
Max. Output < 5 mW Wavelength: 630-660nm, Complies with 21 CFR 1040.10 and 1040.11. Class IIIa Laser Product. (Fig. Y)



- Laser Aperture Label: **AVOID EXPOSURE:** Laser radiation is emitted from this aperture. (Fig. Y)



- **NOTE:** All the adjustments for the operation of this machine have been completed at the factory. Due to normal wear and use, some occasional readjustments may be necessary.
- **CAUTION:** Use of controls or adjustments or performance of procedures other than those specified herein may result in hazardous radiation exposure.
- **CAUTION:** The use of optical instruments with this product will increase eye hazard.
- **WARNING:** Do not attempt to repair or disassemble the laser. If unqualified persons attempt to repair this laser product, serious injury may result. Any repair required on this laser product should be performed by a qualified service dealer.

Fig. Y

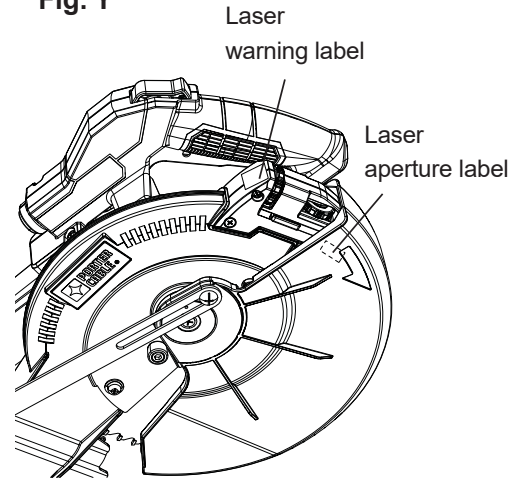

NOTE: If laser labels are missing, damaged or not clear, contact with the Porter-Cable Customer Care Center for replacement.

LASER GUIDE ADJUSTMENT (FIG. Z, AA, BB, CC)

NOTE: All the adjustments for the operation of this machine have been completed at the factory. Due to normal wear and use, some occasional readjustments may be necessary.

⚠ WARNING

To prevent serious injury, insert a padlock (not provided) or chain with padlock through the hole in the ON/OFF Trigger Switch prior to making any laser adjustment. **DO NOT** remove the lock from the ON/OFF Trigger Switch during any laser adjustment.

A. Checking Laser Line Alignment (Fig. Z, BB)

1. Set the saw to a 0° miter and 0° bevel setting.
2. Use a combination square to mark a 90° angle running across the top and down the front of a board. This line will serve as the pattern line (Fig. BB) to adjust the laser. Place the board on the saw table.
3. Carefully lower the saw head down to align the saw blade with the pattern line. Position the saw blade to the left, center or right side of the "pattern line" depending on your preference for the laser line location. Lock board in place with hold-down clamp.
4. With the saw plugged in, turn on the laser guide. Your saw has been preset with the laser line to the left side of the blade.

⚠ WARNING

When making laser line adjustments, keep fingers away from the ON/OFF trigger switch to prevent accidental starting and possible serious injury.

5. Looking at the front of the board, if the laser line is not parallel to the “pattern line” please follow the instructions listed below under “Front Line” paragraph.
6. Looking at the top of the board, if the laser line is not parallel to the “pattern line” please follow the instructions listed below under “Top Line” paragraph.

Fig. Z

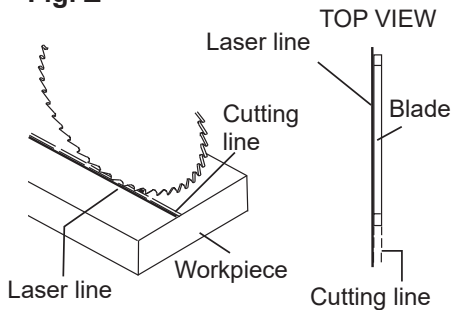

B. Adjusting the Position of the Laser Line (Fig. AA, BB, CC)

Front Line (Fig. AA, BB)

If the laser line is angled from left to right, turn the laser vertical adjustment knob (1) counterclockwise to align the laser line parallel with pattern line. If the laser line is angled from right to left, turn the knob clockwise to align the laser line parallel with pattern line.

Top Line (Fig. AA, CC)

If the laser line is angled from left to right, turn the laser horizontal adjustment knob (2) clockwise to align the laser line parallel with pattern line. If the laser line is angled from right to left, turn the knob counterclockwise to align the laser line parallel with pattern line.

After performing the above adjustments, visually check that both the front and top laser lines are parallel with pattern line.

NOTE:

- Laser line is calibrated and set up at the factory to project to the left of the blade.
- If you have any problem or questions concerning the laser guide, call the Porter-Cable Customer Care Center at (888) 609-9779 .

Fig. AA

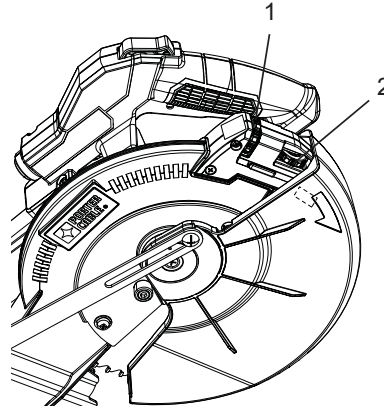

Fig. BB

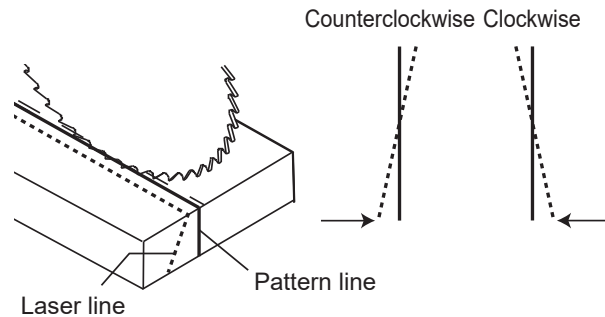
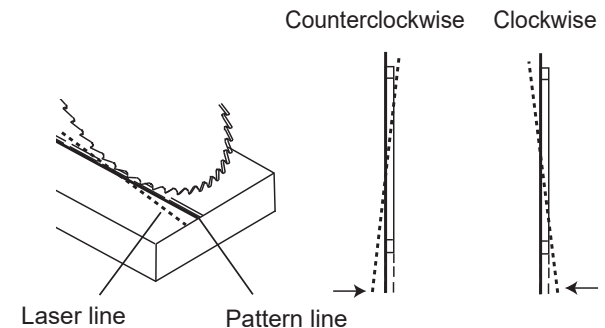

Fig. CC



OPERATION

SAFETY INSTRUCTIONS FOR BASIC SAW OPERATION

⚠ WARNING

- To reduce the risk of injury, turn unit off and disconnect it from power source before installing and removing accessories, before adjusting or when making repairs. An accidental start-up can cause injury.
- To ensure the blade path is clear of obstructions, always make a dry run of the cut without power before making any cuts on the workpiece.

BEFORE USING THE MITER SAW

⚠ WARNING

To avoid mistakes that could cause serious, permanent injury, do not plug the tool in until the following steps are completed:

- Completely assemble and adjust the saw, following the instructions. (**ASSEMBLY & ADJUSTMENTS**)
- Learn the use and function of the ON/OFF trigger switch, on/off switch for laser, upper and lower blade guards, head hold-down latch, bevel lock handle, and cover plate screw.
- Review and understand all safety instructions and operating procedures in this Operator's Manual. (**SAFETY & OPERATION**)
- Review the **MAINTENANCE** and **TROUBLESHOOTING GUIDE** for your miter saw.
- To avoid injury or possible death from electrical shock:
Make sure your fingers do not touch the plug's metal prongs when plugging or unplugging your miter saw. (**ELECTRICAL REQUIREMENTS AND SAFETY**)

BEFORE EACH USE INSPECT YOUR SAW.

- **Disconnect the miter saw.** To avoid injury from accidental starting, unplug the saw before any adjustments, including set-up and blade changes.
- **Compare the direction of rotation arrow** on the guard to the direction arrow on the blade. The blade teeth should always point downward at the front of the saw.
- **Tighten the arbor bolt.**
- **Tighten the cover plate screw.**
- **Check for damaged parts.**
Check for:
 - Alignment of moving parts

- Damaged electric cords
- Binding of moving parts
- Broken/cracked castings: base, table, motor, upper arm
- Function of arm return spring and lower guard: Push the cutting arm all the way down, then let it rise until it stops. The lower guard should fully close. Follow instructions in **TROUBLESHOOTING GUIDE** for adjustment if necessary.
- Other conditions that may affect the way the miter saw works.
- Keep all guards in place, in working order and proper adjustment. If any part of this miter saw is missing, bent, damaged or broken in any way, or any electrical parts don't work, turn the saw off and unplug it.
- Replace bent, damaged, missing or defective parts before using the saw again. All repairs should be done by a certified and licensed technician.
- Maintain tools with care. Keep the miter saw clean for best and safest performance. Follow instructions for lubricating. Do not put lubricants on the blade while it is spinning.
- Remove adjusting wrench from the tool before turning it on.
- To avoid injury from jams, slips, or thrown pieces, use only recommended accessories.
- Check the dust bag before you work. Empty the bag if it is more than half-full.

RECOMMENDED ACCESSORIES

- Consult the **ACCESSORIES** and **ATTACHMENTS** section of this Operator's Manual for recommended accessories. Follow the instructions that come with the accessory. The use of improper accessories may cause risk of injury to persons.
- Choose the correct 10 in. diameter blade for the material and the type of cutting you plan to do.
- Make sure the blade is sharp, undamaged and properly aligned. With the saw unplugged, push the cutting arm all the way down. Manually spin the blade and check for clearance. Tilt the power-head to a 45° bevel and repeat the test.
- Make sure the blade and arbor collars are clean.
- Make sure all clamps and locks are tight and there is no excessive play in any parts.

KEEP YOUR WORK AREA CLEAN

Cluttered areas and benches invite accidents.

WARNING

To avoid burns or other fire damage, never use the miter saw near flammable liquids, vapors, or gases.

- Plan ahead to protect your eyes, hands, face and ears.
- Know your miter saw. Read and understand this Operator's Manual and labels affixed to this tool. Learn its application and limitations as well as the specific potential hazards peculiar to this tool. To avoid injury from accidental contact with moving parts, do not do layout, assembly, or setup work on the miter saw while any parts are moving.
- Avoid accidental starting, make sure the trigger switch is disengaged before plugging the miter saw into a power outlet.

PLAN YOUR WORK

- Use the right tool. Don't force a tool or attachment to do a job it was not designed to do. Use a different tool for any workpiece that can't be held in a solidly braced, fixed position.

CAUTION

This machine is not designed for cutting masonry, masonry products, ferrous metals (steel, iron, and iron-based metals.) Use this miter saw to cut only wood, wood-like products, or non-ferrous metals. Other material may shatter, bind the blade, or create other dangers. Do not use this saw to cut tree limbs or logs. Remove all nails that may be in the workpiece to prevent sparking that could cause a fire. Remove dust bag when cutting non-ferrous metals.

DRESS FOR SAFETY



Any power tool can throw foreign objects into the eyes. This can result in permanent eye damage. Everyday eyeglasses have only impact resistant lenses and are not safety glasses. Glasses or goggles not in compliance with ANSI Z87.1 could seriously injure you when they break.

- Do not wear loose clothing, gloves, neckties or jewelry (rings, watches). They can get caught and draw you into moving parts.
- Wear non-slip footwear.

- Tie back long hair.
- Roll long sleeves above the elbow.
- Noise levels vary widely. To avoid possible hearing damage, wear ear plugs when using any miter saw.
- Always wear a face mask or dust mask along with safety goggles.

INSPECT YOUR WORKPIECE

- Make sure there are no nails or foreign objects in the part of the workpiece being cut.
- Plan your work to avoid small pieces that may bind or are too small to clamp and hold securely.
- Plan the way you will grasp the workpiece from start to finish. Avoid awkward operations and hand positions. A sudden slip could cause your fingers or hand to move into the blade.

DO NOT OVER-REACH

Keep good footing and balance. Keep your face and body to one side, out of the line of a possible kickback. NEVER stand in the line of the blade.

Never cut freehand:

- Brace your workpiece firmly against the fence and table stop so it will not rock or twist during the cut.
- Make sure there is no debris between the workpiece and the table or fence.
- Make sure there are no gaps between the workpiece, fence and table that will let the workpiece shift after it is cut.
- Keep the cut off piece free to move sideways after it is cut off. Otherwise, it could get wedged against the blade and thrown violently.
- Only the workpiece should be on the saw table.
- Secure work. Use clamps or a vice to help hold the work.

USE EXTRA CAUTION WITH LARGE OR ODD SHAPED WORKPIECES.

- Use extra supports (tables, sawhorses, blocks, etc.) for workpieces large enough to tip.
- Never use another person as a substitute for a table extension, or as an additional support for a workpiece that is longer or wider than the basic miter saw table, or to help feed, support, or pull the workpiece.

- Do not use this saw to cut small pieces. If the workpiece being cut would cause your hand or fingers to be within 7-5/16 in. of the saw blade the workpiece is too small. Keep hands and fingers out of the “no-hands zone” area marked on the saw table.
- When cutting odd shaped workpieces, plan your work so it will not bind in the blade and cause possible injury. Molding, for example, must lie flat or be held by a fixture or jig that will not let it move when cut.
- Properly support round material such as dowel rods, or tubing, which have a tendency to roll when cut.

⚠ WARNING

To avoid injury, follow all applicable safety instructions, when cutting non-ferrous metals:

- Use only saw blades specifically recommended for non-ferrous metal cutting.
- Do not cut metal workpieces that must be hand held. Clamp workpieces securely.
- Cut non-ferrous metals only if you are under the supervision of an experienced person and the dust bag has been removed from the saw.

WHEN SAW IS RUNNING

⚠ WARNING

Do not allow familiarity from frequent use of your miter saw to result in a careless mistake. A careless fraction of a second is enough to cause a severe injury.

Before cutting, if the saw makes an unfamiliar noise or vibrates, stop immediately. Turn the saw OFF. Unplug the saw. Do not restart until finding and correcting the problem.

MAKING A BASIC CUT

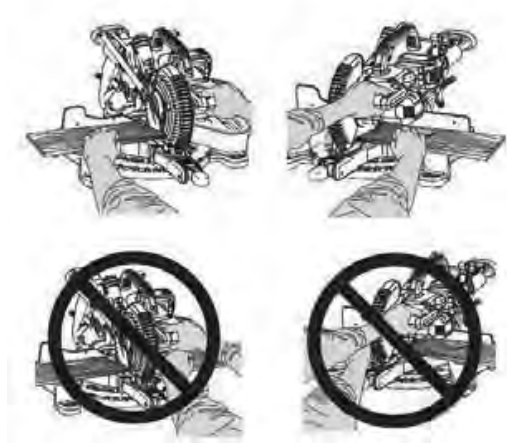

⚠ WARNING

To ensure the blade path is clear of obstructions, always make a dry run of the cut without power before making any cuts on the workpiece.

Body and Hand Position (Fig. DD)



Never place hands near the cutting area. Proper positioning of your body and hands when operating the miter saw will make cutting easier and safer. Keep children away. Keep all visitors at a safe distance from the miter saw. Make sure bystanders are clear of the saw and workpiece. Don't force the saw.

Starting a cut:

- Place hands at least 7-5/16 in. away from the path of the blade – out of the “no-hands zone” (1) shown in Fig. DD on the next page.
- Always use the clamp to firmly hold the workpiece against the fence and table to prevent movement toward the blade.
- Turn the laser guide on for pre-alignment of your cut.
- With the power switch OFF, bring the saw blade down to the workpiece to see the cutting path of the blade. Raise the saw blade back up before turning the saw on.
- Squeeze trigger switch to start saw.
- Lower blade into workpiece with a firm downward motion.

Finishing a cut:

- Hold the cutting arm in the down position.
- Release trigger switch and wait for all moving parts to stop before moving your hands and raising the cutting arm.
- If the blade doesn't stop within 10 seconds, unplug the saw and follow the instructions in TROUBLESHOOTING GUIDE section.

Before freeing jammed material:

- Release trigger switch.
- Wait for all moving parts to stop.
- Unplug the miter saw.

Fig. DD

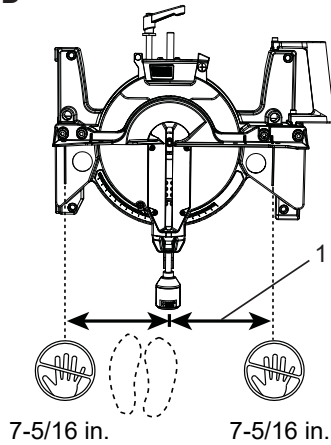

BASIC SAW OPERATIONS

⚠ WARNING

For your convenience, your saw has a blade brake. The brake is not a safety device. Never rely on it to replace the proper use of the guard on your saw. If the blade doesn't stop within approximately 10 seconds, wait for the blade to stop, unplug the saw and contact Porter-Cable or another qualified service dealer.

TURNING THE SAW ON (FIG. EE)

This miter saw is equipped with an ON/OFF trigger switch (1). With the safety lock (2) pressed, squeeze the trigger switch to turn the miter saw ON.

NOTE:

- To make the ON/OFF switch childproof. Insert a padlock (not provided), or chain with padlock, through the hole (3) in the trigger switch. Locking the tool's switch, preventing children and other unqualified users from turning the machine on.
- The miter saw is equipped with an electric blade brake. When the trigger switch is released, the blade brake will stop the blade within approximately 10 seconds.

Fig. EE

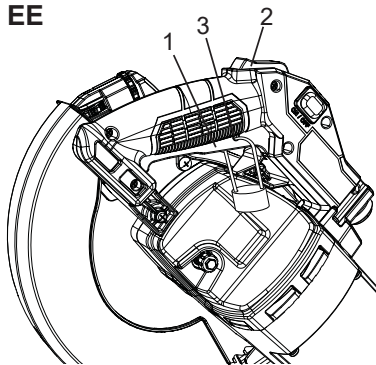

BEFORE LEAVING THE SAW

- Never leave tool running unattended. Turn power OFF. Wait for all moving parts to stop.
- Make workshop childproof. Lock the shop. Disconnect master switches. Store tool away from children and other unqualified users.

⚠ WARNING

To avoid injury from materials being thrown, always unplug the saw to avoid accidental starting, and remove small pieces of material from the table cavity. The table insert may be removed for this purpose, but always reattach the table insert prior to performing a cutting operation.

MITER CUT (FIG. FF, GG)

1. When a miter cut is required, unlock the miter table by turning the miter handle (1) counterclockwise.
 2. While holding the miter handle, lift up on the positive stop locking lever (2).
 3. Rotate the miter table to the right or left with the miter handle.
 4. When the table is in the desired position, as shown on the miter scale (3), release the positive stop locking lever and tighten the miter handle. The table is now locked at the desired angle. Positive stops are provided at 0°, 15°, 22.5°, 31.6°, 45° right & left, and 55° right.
- IMPORTANT:** Always tighten the miter handle (1) before performing every cutting operation.
5. Turn the laser guide on and position the workpiece on the table for pre-alignment of your cut.

⚠ WARNING

To avoid the bevel lock handle (4) interfering with the miter saw base (5) when the right miter angle is greater than 30°, pull the bevel lock handle to adjust the direction not to point downward shown in Fig. GG.

Fig. FF

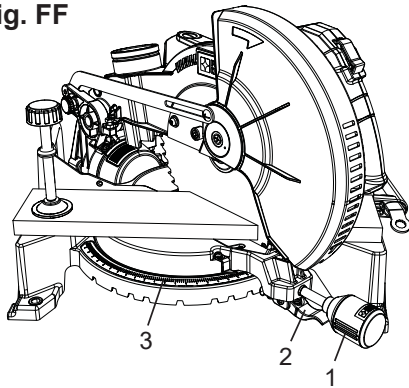
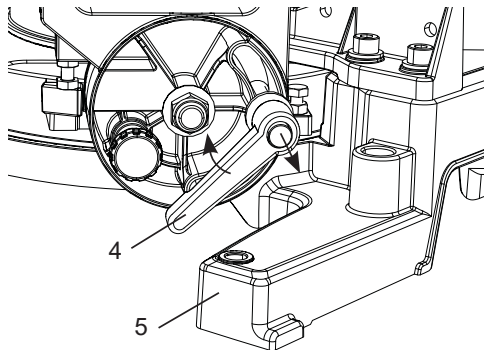

Fig. GG



BEVEL CUT (FIG. HH)

⚠ WARNING

NEVER BEVEL to the right, this saw is designed to only be used for cutting left bevel cuts.

1. When a bevel cut is required, loosen the bevel lock handle (1) by turning it clockwise.
2. Tilt the cutting head to the desired angle, as shown on the bevel scale (2).
3. The blade can be positioned at any angle, from a 90° straight cut (0° on the scale) to a 47° left bevel. Tighten the bevel lock handle (1) to lock the cutting head in position.
4. Turn the laser guide on and position the workpiece on the table for pre-alignment of your cut.

Fig. HH

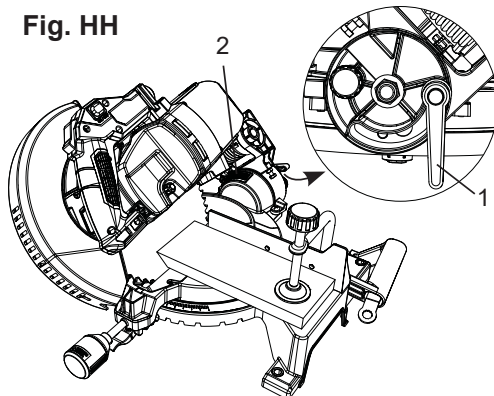

COMPOUND CUT (FIG. GG, II)

⚠ WARNING

NEVER BEVEL to the right, this saw is designed to only be used for cutting left bevel cuts.

A compound cut is the combination of a miter and a bevel cut simultaneously.

1. Loosen the miter handle (1). Lift up the positive stop locking lever (2) and position the table at the desired angle. Release the positive stop locking lever (2) and lock the miter handle (1). (Fig. II)
2. Loosen the bevel lock handle (3) and position the cutting head at the desired bevel position. Lock the bevel lock handle (3).
3. Turn the laser guide on and position the workpiece on the table for pre-alignment of your cut.

⚠ WARNING

- To avoid the bevel lock handle (4) interfering with the miter saw base (5) when the right miter angle is greater than 30°, pull the bevel lock handle to adjust the direction not to point downward shown in Fig. GG.
- As the right miter angle is greater than 48°, do not combine with any bevel angle to prevent the interference.

Fig. II

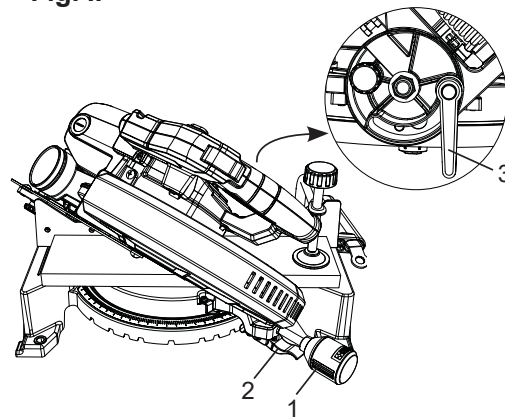

CUTTING BOWED MATERIAL (FIG. JJ)

⚠ WARNING

To avoid injury from materials being thrown, always unplug the saw to avoid accidental starting and remove small pieces of material from the table cavity underlying the table insert.

The table insert may be removed for this purpose, but always reattach table insert prior to performing a cutting operation.

A bowed workpiece (1) must be positioned against the fence and secured with a hold-down clamp (2) as shown before cutting. Do not position workpiece incorrectly or try to cut the workpiece without the support of the fence. This will cause the blade to bind and could result in personal injury.

Fig. JJ

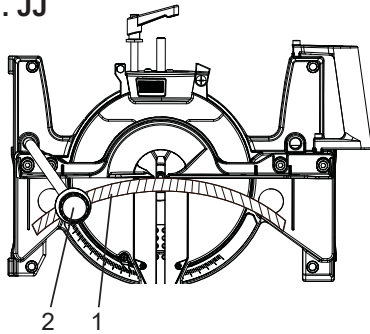

WORKPIECE SUPPORT (FIG. KK)

Long pieces need extra support. The support should be placed under the workpiece. Keep your hand holding the workpiece positioned 7-5/16 inches or more away from the blade. The support must let the workpiece lay flat on the work table during the cutting operation.

NOTE: When mounted on a flat surface, the saw table is 3-1/2 inches high.

Fig. KK

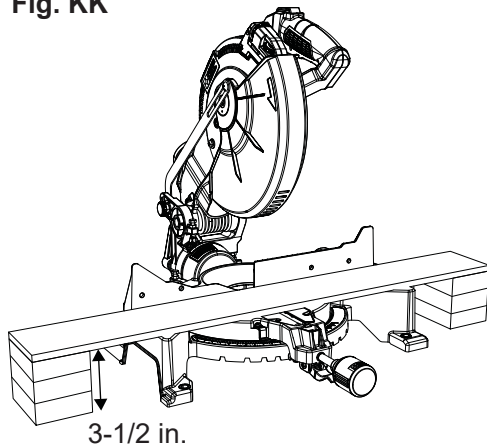

SUPPORT BASE AS EXTENSION TABLE (FIG. LL)

⚠ WARNING

Before using, make sure the height of the saw table matches the height of the support base.

1. Place the miter saw and support base (1) on a flat, stable surface with the support base on the side of the miter saw where the support is needed.
2. Adjust the position of the support base according to the length of the workpiece to provide extra support.

Fig. LL

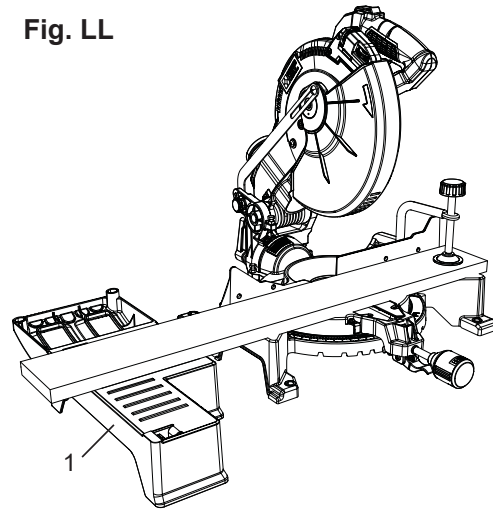

AUXILIARY WOOD FENCE (FIG. MM)

When making multiple or repetitive cuts that result in cut-off pieces of one inch or less, it is possible for the saw blade to catch the cut-off piece and throw it out of the saw or into the blade guard and housing, possibly causing damage or injury. To minimize this, an auxiliary wood fence can be mounted to your saw.

Holes are provided in the saw fence to attach an auxiliary wood fence. This fence is to be constructed of straight wood approximately 3/4 in. thick by 2-1/2 in. high by 22 in. long.

Attach the wood fence securely and make a full depth cut to make a blade slot.

Check for interference between the wood fence and the lower blade guard. Adjust if necessary.

NOTE: This auxiliary fence is used only with the saw blade in the 0° bevel position (90° to the table). The auxiliary wood fence must be removed when bevel cutting.

Fig. MM

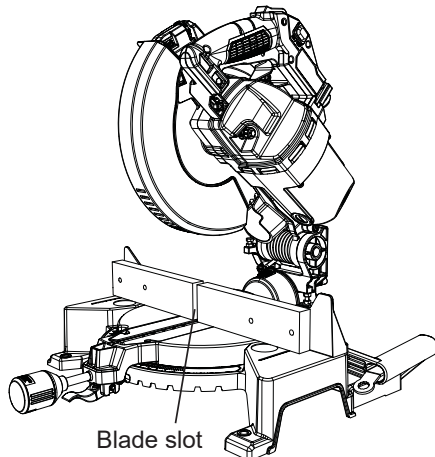

CUTTING BASE MOLDING (FIG. NN)

Base moldings and many other moldings can be cut on a compound miter saw. The setup of the saw depends on molding characteristics and application, as shown. Perform practice cuts on scrap material to achieve best results:

1. Always make sure moldings rest firmly against fence and table. Use hold-down, crown molding vice or C-clamps, whenever possible, and place tape on the area being clamped to avoid marks.
2. Reduce splintering by taping the cut area prior to making the cut. Mark the cut line directly on the tape.
3. Splintering typically happens due to an incorrect blade application and thinness of the material.

Fig. NN

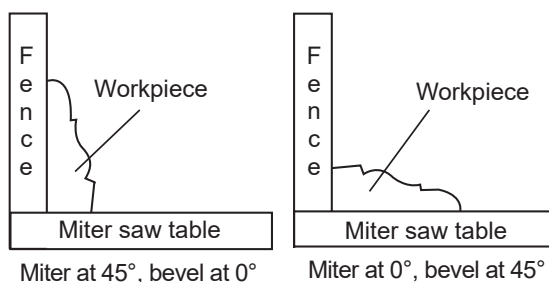

CUTTING CROWN MOLDING (FIG. OO, PP)

Your compound miter saw is suited for the difficult task of cutting crown molding. To fit properly, crown molding must be compound-mitered with extreme accuracy. The two surfaces on a piece of crown molding that fit flat against the ceiling and wall are at angles that, **when added together, equal exactly 90°.**

Most crown molding has a top rear angle (the section that fits flat against the ceiling) of 52° and a bottom rear angle (the section that fits flat against the wall) of 38°.

In order to accurately cut crown molding for a 90° inside or outside corner, lay the molding with its broad back surface flat on the saw table.

When setting the bevel and miter angles for compound miters, remember that the settings are interdependent.

Fig. OO

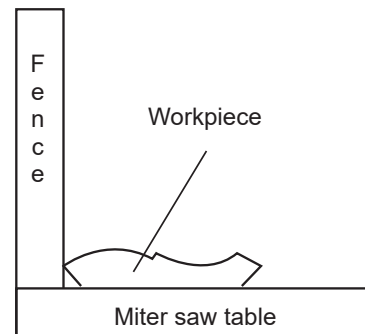

Fig. PP

Settings for standard crown molding lying flat on compound miter saw table

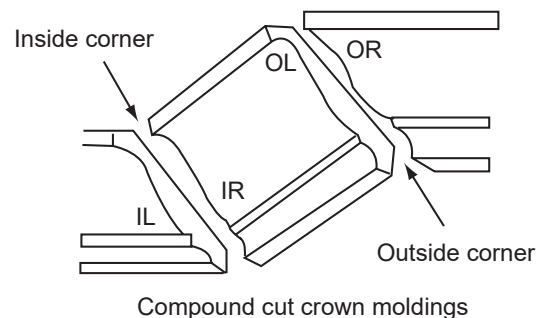
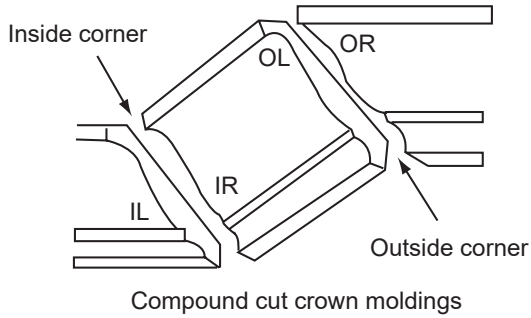

Fig. PP

Settings for standard crown molding lying flat on compound miter saw table



Bevel/Miter Settings

NOTE: The chart below references a compound cut for crown molding ONLY WHEN THE ANGLE BETWEEN THE WALLS EQUALS EXACTLY 90°.

KEY	BEVEL ANGLE SETTING	MITER ANGLE SETTING	TYPE OF CUT
			Inside Corner - Left Side
IL	33.9°	31.6° Right	1. Position top of molding against fence. 2. LEFT side is finished piece.
			Inside Corner - Right Side
IR	33.9°	31.6° Left	1. Position bottom of molding against fence. 2. LEFT side is finished piece.
			Outside Corner-Left Side
OL	33.9°	31.6° Left	1. Position bottom of molding against fence. 2. RIGHT side is finished piece.
			Outside Corner - Right Side
OR	33.9°	31.6° Right	1. Position top of molding against fence. 2. RIGHT side is finished piece.

CROWN MOLDING CHART
Compound Miter Saw
Miter and Bevel Angle Settings
Wall to Crown Molding Angle

Angle Between Walls	52/38° Crown Molding		45/45° Crown Molding	
	Miter Setting	Bevel Setting	Miter Setting	Bevel Setting
67	42.93	41.08	46.89	36.13
68	42.39	40.79	46.35	35.89
69	41.85	40.50	45.81	35.64
70	41.32	40.20	45.28	35.40
71	40.79	39.90	44.75	35.15
72	40.28	39.61	44.22	34.89
73	39.76	39.30	43.70	34.64
74	39.25	39.00	43.18	35.38
75	38.74	38.69	42.66	34.12
76	38.24	38.39	42.15	33.86
77	37.74	38.08	41.64	33.60
78	37.24	37.76	41.13	33.33
79	36.75	37.45	40.62	33.07
80	36.27	37.13	40.12	32.80
81	35.79	36.81	39.62	32.53
82	35.31	36.49	39.13	32.25
83	34.83	36.17	38.63	31.98
84	34.36	35.85	38.14	31.70
85	33.90	35.52	37.66	31.42
86	33.43	35.19	37.17	31.14
87	32.97	34.86	36.69	30.86
88	32.52	34.53	36.21	30.57
89	32.07	34.20	35.74	30.29
90	31.62	33.86	35.26	30.00
91	31.17	33.53	34.79	29.71
92	30.73	33.19	34.33	29.42
93	30.30	32.86	33.86	29.13
94	29.86	32.51	33.40	28.83
95	29.43	32.17	32.94	28.54
96	29.00	31.82	32.48	28.24
97	28.58	31.48	32.02	27.94
98	28.16	31.13	31.58	27.64
99	27.74	30.78	31.13	27.34
100	27.32	30.43	30.68	27.03
101	26.91	30.08	30.24	26.73
102	26.50	29.73	29.80	26.42
103	26.09	29.38	29.36	26.12
104	25.69	29.02	28.92	25.81
105	25.29	28.67	28.48	25.50
106	24.89	28.31	28.05	25.19
107	24.49	27.96	27.62	24.87
108	24.10	27.59	27.19	24.56
109	23.71	27.23	26.77	24.24
110	23.32	26.87	26.34	23.93
111	22.93	26.51	25.92	23.61
112	22.55	26.15	25.50	23.29
113	22.17	25.78	25.08	22.97
114	21.79	25.42	24.66	22.66
115	21.42	25.05	24.25	22.33
116	21.04	24.68	23.84	22.01
117	20.67	24.31	23.43	21.68
118	20.30	23.94	23.02	21.36
119	19.93	23.57	22.61	21.03
120	19.57	23.20	22.21	20.70
121	19.20	22.83	21.80	20.38
122	18.84	22.46	21.40	20.05
123	18.48	22.09	21.00	19.72

Angle Between Walls	52/38° Crown Molding		45/45° Crown Molding	
	Miter Setting	Bevel Setting	Miter Setting	Bevel Setting
124	18.13	21.71	20.61	19.39
125	17.77	21.34	20.21	19.06
126	17.42	20.96	19.81	18.72
127	17.06	20.59	19.42	18.39
128	16.71	20.21	19.03	18.06
129	16.37	19.83	18.64	17.72
130	16.02	19.45	18.25	17.39
131	15.67	19.07	17.86	17.05
132	15.33	18.69	17.48	16.71
133	14.99	18.31	17.09	16.38
134	14.66	17.93	16.71	16.04
135	14.30	17.55	16.32	15.70
136	13.97	17.17	15.94	15.36
137	13.63	16.79	15.56	15.02
138	13.30	16.40	15.19	14.62
139	12.96	16.02	14.81	14.34
140	12.63	15.64	14.43	14.00
141	12.30	15.25	14.06	13.65
142	11.97	14.87	13.68	13.31
143	11.64	14.48	13.31	12.97
144	11.31	14.09	12.94	12.62
145	10.99	13.71	12.57	12.29
146	10.66	13.32	12.20	11.93
147	10.34	12.93	11.83	11.59
148	10.01	12.54	11.46	11.24
149	9.69	12.16	11.09	10.89
150	9.37	11.77	10.73	10.55
151	9.05	11.38	10.36	10.20
152	8.73	10.99	10.00	9.85
153	8.41	10.60	9.63	9.50
154	8.09	10.21	9.27	9.15
155	7.77	9.82	8.91	8.80
156	7.46	9.43	8.55	8.45
157	7.14	9.04	8.19	8.10
158	6.82	8.65	7.83	7.75
159	6.51	8.26	7.47	7.40
160	6.20	7.86	7.11	7.05
161	5.88	7.47	6.75	6.70
162	5.57	7.08	6.39	6.35
163	5.26	6.69	6.03	6.00
164	4.95	6.30	5.68	5.65
165	4.63	5.90	5.32	5.30
166	4.32	5.51	4.96	4.94
167	4.01	5.12	4.61	4.59
168	3.70	4.72	4.25	4.24
169	3.39	4.33	3.90	3.89
170	3.08	3.94	3.54	3.53
171	2.77	3.54	3.19	3.10
172	2.47	3.15	2.83	2.83
173	2.15	2.75	2.48	2.47
174	1.85	2.36	2.12	2.12
175	1.54	1.97	1.77	1.77
176	1.23	1.58	1.41	1.41
177	0.92	1.18	1.06	1.06
178	0.62	0.79	0.71	0.71
179	0.31	0.39	0.35	0.35

MAINTENANCE

⚠ WARNING

To reduce the risk of injury, turn unit off and disconnect it from power source before installing and removing accessories, before adjusting or when making repairs. An accidental start-up can cause injury.

MAINTENANCE

⚠ DANGER

To avoid injury, never put lubricants on the blade while it is spinning.

⚠ WARNING

- To avoid fire or toxic reaction, never use gasoline, naphtha acetone, lacquer thinner or similar highly volatile solvents to clean the miter saw.
- To avoid injury from unexpected starting or electrical shock, unplug the power cord before working on the saw.
- To avoid electrical shock, fire or injury, use only parts identical to those identified in the parts list. Reassemble exactly as the original assembly to avoid electrical shock.

REPLACING CARBON BRUSHES (FIG. QQ)

The carbon brushes furnished will last approximately 50 hours of running time, or 10,000 ON/OFF cycles. Replace both carbon brushes when either has less than 1/4 in. length of carbon remaining, or if the spring or wire is damaged or burned. To inspect or replace brushes, first unplug the saw. Then remove the black plastic cap (1) on the side of the motor (2). Remove the cap cautiously, because it is springloaded. Then pull out the carbon brush (3) and replace. To reassemble, reverse the procedure. The ears on the metal end of the assembly go in the same hole the carbon part fits into. Tighten the cap snugly, but do not overtighten. Repeat for the carbon brush located on the other side of motor.

NOTE: To reinstall the same brushes, first make sure the brushes go back in the way they came out. This will avoid a break-in period that reduces motor performance and increases wear.

Fig. QQ

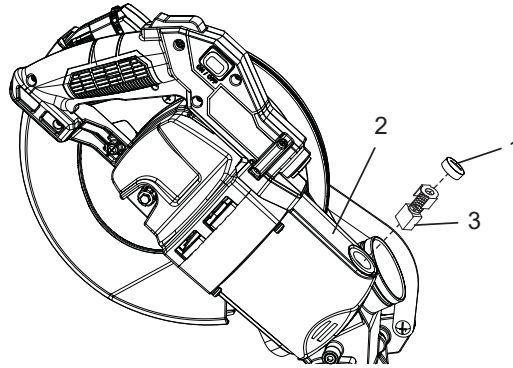

LOWER BLADE GUARD

Do not use the saw without the lower blade guard. The lower blade guard is attached to the saw for your protection. Should the lower guard become damaged, do not use the saw until the damaged guard has been replaced. Regularly check to make sure the lower guard is working properly. Also check before each use that all bolts/screws are tight. Clean the lower guard of any dust or buildup with a damp cloth.

⚠ WARNING

- When cleaning the lower guard, unplug the saw from the power source receptacle to avoid unexpected start-up.
- Do not use solvents on the guard. They could make the plastic “cloudy” and brittle.

SAWDUST

Periodically, sawdust will accumulate under the work table and base. This could cause difficulty in the movement of the worktable when setting up a miter cut. Frequently blow out or vacuum up the sawdust.

Remove small pieces of material from the table cavity if needed. (See the section on REMOVING AND INSTALLING THE TABLE INSERT on page 20.)

To empty the dust bag, remove the sawdust bag from the dust collection elbow. Open the zipper on the sawdust bag and empty out the sawdust inside. Close the zipper and reinstall the dust bag as described on page 16.

⚠ WARNING

Wear proper eye protection to keep debris from entering eyes when removing sawdust from unit.

LUBRICATION (FIG. RR)

All the motor bearings in this tool are lubricated with a sufficient amount of high grade lubricant for the life of the unit under normal operating conditions; therefore, no further lubrication is required.

Lubricate the following as necessary:

Chop pivot: Apply light machine oil to points indicated in illustration.

Central pivot of plastic guard: Use light household oil (sewing machine oil) on metal-to-metal or metal-to-plastic guard contact areas as required for smooth, quiet operation. Avoid excessive oil, to which sawdust will cling.

Fig. RR

Central pivot of plastic guard (oil here)

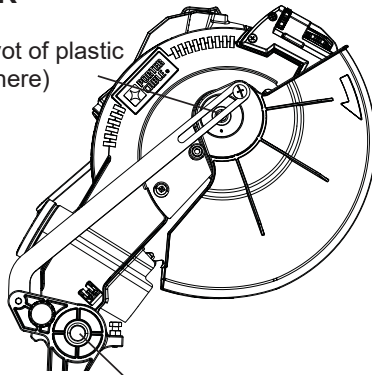

Chop Pivot (oil here and on opposite side)



FREE WARNING LABEL REPLACEMENT:

If your warning labels become illegible or are missing, call 1-888-609-9779 for a free replacement.

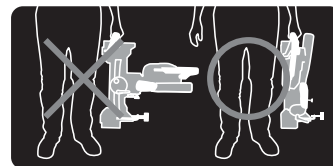
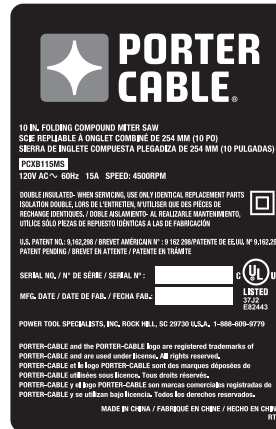

⚠ ADVERTENCIA POR SU PROPIA SEGURIDAD LEA EL MANUAL DE INSTRUCCIONES ANTES DE UTILIZAR LA SIERRA DE INGLETES

1. UTILICE PROTECCIÓN OCULAR.
2. UTILICE PROTECCIÓN RESPIRATORIA Y AUDITIVA.
3. MANTENGA LAS MANOS FUERA DE LA TRAYECTORIA DE LA HOJA DE SIERRA.
4. NO HAGÁ FUNCIONAR LA SIERRA SI LOS PROTECTORES NO ESTÁN COLOCADOS EN SU LUGAR.
5. NO UTILICE ÚNICAMENTE LAS MANOS PARA EL FUNCIONAMIENTO.
6. NUNCA TOQUE ALREDEDOR O ENCIMA DE LA HOJA DE LA SIERRA.
7. APAGUE LA HERRAMIENTA Y ESPERE QUE LA HOJA DE LA SIERRA SE DETENGA ANTES DE MOVER LAS PIEZAS DE TRABAJO O DE CAMBIAR LA CONFIGURACIÓN.
8. DESCONECTE LA ELECTRICIDAD ANTES DE CAMBIAR LA HOJA O REALIZARLE MANTENIMIENTO.
9. USE SÓLO HOJA QUE TENGAN 25,4 CM DE DIÁMETRO Y UNA VELOCIDAD MÁXIMA SUPERIOR A 4500 R.P.M. (LA VELOCIDAD EN VACÍO DE ESTA SIERRA ES DE 4500 R.P.M.).
10. NO LA EXPONGA A LA LLUVIA NI LA USE EN LUGARES HÚMEDOS.
11. AJUSTE EL TORNILLO DE LA VARILLA DE SUJECIÓN Y LOS GANCHOS DE SEGURIDAD ANTES DE PONER LA MÁQUINA EN FUNCIONAMIENTO.
12. SUJETE LA HERRAMIENTA PARA EVITAR MOVIMIENTOS IMPREVISTOS.
13. SI NO CUMPLE ESTAS ADVERTENCIAS Y OTRAS QUE SE ENCUENTRAN EN EL MANUAL, PUEDE ORIGINAR LESIONES PERSONALES GRAVES.

⚠ WARNING FOR YOUR OWN SAFETY READ INSTRUCTION MANUAL BEFORE OPERATING MITER SAW

1. WEAR EYE PROTECTION.
2. WEAR RESPIRATORY AND HEARING PROTECTION.
3. KEEP HANDS OUT OF PATH OF SAW BLADE.
4. DO NOT OPERATE SAW WITHOUT GUARDS IN PLACE.
5. DO NOT PERFORM ANY OPERATION FREEHAND.
6. NEVER REACH AROUND SAW BLADE.
7. TURN OFF TOOL AND WAIT FOR SAW BLADE TO STOP BEFORE MOVING WORKPIECE OR CHANGING SETTINGS.
8. DISCONNECT POWER BEFORE CHANGING BLADE OR SERVICING.
9. USE ONLY BLADES THAT ARE 10 IN. DIAMETER AND HAVE A MAXIMUM RPM SPEED GREATER THAN 4500RPM (NO LOAD ON THIS SAW IS 4500RPM).
10. DO NOT EXPOSE TO RAIN OR USE IN DAMP LOCATIONS.
11. TIGHTEN ARBOR SCREW AND CLAMPS BEFORE SAWING.
12. SECURE TOOL PROPERLY TO PREVENT UNEXPECTED MOVEMENT.
13. FAILURE TO COMPLY WITH THESE WARNINGS MAY RESULT IN SERIOUS PERSONAL INJURY.

⚠ AVERTISSEMENT POUR VOTRE SÉCURITÉ, LIRE LE GUIDE D'UTILISATION AVANT D'UTILISER LA SCIE À ONGLETS

1. PORTEZ UNE PROTECTION DES YEUX.
2. PORTEZ UNE PROTECTION RESPIRATOIRE ET UNE PROTECTION OCULAIRE.
3. GARDEZ LES MAINS HORS DU CHEMIN DE LA LAME DE SCIE.
4. N'UTILISEZ PAS LA SCIE SI LES DISPOSITIFS DE PROTECTION NE SONT PAS EN PLACE.
5. NE PAS UTILISER L'APPAREIL À MAIN LIBRE.
6. N'ESSAYEZ JAMAIS D'ATTEINDRE QUELQUE CHOSE SE TROUVANT À PROXIMITÉ DE LA LAME DE SCIE.
7. ARRÊTER L'APPAREIL ET ATTENDRE QUE LA LAME S'IMMOBILISE AVANT DE DÉPLACER LES PIÈCES DE BOIS OU DE CHANGER LES RÉGLAGES.
8. COUPEZ L'ALIMENTATION ÉLECTRIQUE AVANT DE CHANGER DE LAME OU DE PROCÉDER À L'ENTRETIEN.
9. UTILISEZ SEULEMENT DES LAMES MESURANT ENVIRON 25,4 CM (10 PO) DE DIAMÈTRE ET AVANT UNE VITESSE MAXIMALE SUPÉRIEURE À 4500 T/M (LA VITESSE À VIDE POUR CETTE SCIE EST DE 4500 T/M).
10. N'EXPOSEZ PAS CET OUTIL À LA PLUIE ET NE L'UTILISEZ PAS DANS DES ENDROITS HUMIDES.
11. SERREZ LA VIS ET LES SERRES DE L'ARBRE AVANT DE COMMENCER À SCIER.
12. FIXER SOLIDEMENT L'OUTIL EN PLACE POUR ÉVITER TOUT MOUVEMENT IMPRÉVU.
13. LE DÉFAUT D'OBSERVER CES MISES EN GARDE PEUT ENTRAÎNER DES BLESSURES CORPORELLES GRAVES.

TROUBLESHOOTING GUIDE

WARNING

To avoid injury from an accidental start, turn the switch OFF and always remove the plug from the power source before making any adjustments.

REPLACEMENT PARTS

Use only identical replacement parts. For a parts list or to order parts, visit our service website at www.portercable.com. You can also order parts from your nearest Porter-Cable Factory Service Center or Porter-Cable Authorized Warranty Service Center. Or, you can call our Customer Care Center at (888) 609-9779.

SERVICE AND REPAIRS

All quality tools will eventually require servicing and/or replacement of parts. For information about Porter-Cable, its factory service centers or authorized warranty service centers, visit our website at www.portercable.com or call our Customer Care Center at (888) 609-9779. All repairs made by our service centers are fully guaranteed against defective material and workmanship. We cannot guarantee repairs made or attempted by others.

You can also write to us for information at Power Tool Specialists, Inc. 684 Huey Road, Rock Hill, SC 29730, - Attention: Product Service. Be sure to include all of the information shown on the nameplate of your tool (model number, type, serial number, etc.).

PLEASE READ THE FOLLOWING: The manufacturer and/or distributor is providing the buyer with a parts list and assembly diagram in this manual as a reference tool only. Neither the manufacturer nor distributor make any representation or warranty of any kind to the buyer regarding the accuracy of the list or diagram or that buyer is qualified and able to make any repairs or replace any parts of the product. The manufacturer and/or distributor expressly recommend: that all repairs and/or part replacements only be undertaken by a certified and licensed technician, and not by the buyer. The buyer assumes all risk and liability, including injuries to persons and damage to property, associated with and arising out of any attempt of the buyer at repairs or replacement of parts to the product.

MOTOR

PROBLEM	PROBLEM CAUSE	SUGGESTED CORRECTIVE ACTION
Brake does not stop the blade within 10 seconds.	<ol style="list-style-type: none"> 1. Motor brushes not sealed or lightly sticking. 2. Motor brake overheated from use of defective or wrong size blade or rapid ON/OFF cycling. 3. Arbor bolt loose. 4. Brushes cracked, damaged, etc. 5. Other. 	<ol style="list-style-type: none"> 1. Inspect/clean/replace brushes. See MAINTENANCE section. 2. Use a recommended blade. Let cool down. See REMOVING OR INSTALLING THE BLADE section. 3. Retighten. See REMOVING OR INSTALLING THE BLADE section. 4. Replace brushes. 5. Contact Porter-Cable Service Center or Authorized Service Station.
Motor does not start.	<ol style="list-style-type: none"> 1. Limit switch failure 2. Brush worn. 3. Fuse blown or circuit breaker tripped on home panel. 	<ol style="list-style-type: none"> 1. Replace limit switch. 2. Replace brushes. See MAINTENANCE section. 3. Verify there is electrical power at the outlet.
Brush spark when switch released.	<ol style="list-style-type: none"> 1. Brush worn. 2. Other. 	<ol style="list-style-type: none"> 1. Replace Brushes. See MAINTENANCE section. 2. Contact Porter-Cable Service Center or Authorized Service Station.

SAW OPERATION

PROBLEM	PROBLEM CAUSE	SUGGESTED CORRECTIVE ACTION
Blade hits table.	1. Misalignment.	1. Contact Porter-Cable Service Center or Authorized Service Station.
Angle of cut not accurate. Can not adjust miter.	1. Miter table unlocked. 2. Sawdust under table.	1. See OPERATION - Miter Angle Adjustment section. 2. Vacuum or blow out dust. WEAR EYE PROTECTION.
Cutting arm wobbles.	1. Loose pivot points.	1. Contact Porter-Cable Service Center or Authorized Service Station.
Cutting arm will not fully raise, or blade guard won't fully close.	1. Pivot spring not replaced properly after service. 2. Sawdust build-up.	1. Contact Porter-Cable Service Center or Authorized Service Station. 2. Clean and lubricate moving parts.
Blade binds, jams, burns wood.	1. Improper operation. 2. Dull or warped blade. 3. Improper blade size. 4. Wood is moving during cut.	1. See BASIC SAW OPERATION section. 2. Replace or sharpen blade. 3. Replace with 10 in. (254 mm) diameter blade. 4. Use hold down clamp to secure workpiece to table.
Saw vibrates or shakes.	1. Saw blade not round / damaged / loose. 2. Arbor bolt loose.	1. Replace blade. 2. Tighten arbor bolt.

For assistance with your product, visit our website at www.portercable.com for a list of service centers, or call the Porter-Cable Customer Care Center at (888) 609-9779.

ACCESSORIES AND ATTACHMENTS

RECOMMENDED ACCESSORIES

⚠ WARNING

- Use only accessories recommended for this miter saw. Follow instructions that accompany accessories. Use of improper accessories may cause hazards.
- The use of any cutting tool except 10 in. (254 mm) saw blades which meet the requirements under recommended accessories is prohibited. Do not use accessories such as shaper cutters or dado sets. Ferrous metal cutting and the use of abrasive wheels is prohibited.
- Do not attempt to modify this tool or create accessories not recommended for use with this tool. Any such alteration or modification is misuse and could result in a hazardous condition leading to possible serious injury.

ACCESSORIES

Since accessories, other than those offered by Porter-Cable, have not been tested with this product, use of such accessories with this tool could be hazardous. To reduce the risk of injury, only Porter-Cable recommended accessories should be used with this product.

A complete line of accessories is available from your Porter-Cable Factory Service Center or a Porter-Cable Authorized Warranty Service Center. Please visit our Web Site www.portercable.com for a catalog or for the name of your nearest supplier.

⚠ WARNING

- To avoid the risk of personal injury, do not modify this power tool or use accessories not recommended by Porter-Cable.
- Read warnings and conditions on your **CARBIDE TIPPED SAW BLADE**. Do not operate the saw without the proper saw blade guard in place. Carbide is a very hard but brittle material. Care should be taken while mounting, using, and storing carbide tipped blades to prevent accidental damage. Slight shocks, such as striking the tip while handling, can seriously damage the blade. Foreign objects in the workpiece, such as wire or nails, can also cause tips to crack or break off. Before using, always visually examine the blade and tips for bent blade, cracks, breakage, missing or loose tips, or other damage. Do not use if damage is suspected. Failure to heed safety instructions and warnings can result in serious bodily injury.

⚠ WARNING

Do not use any accessory unless you have completely read the Instruction Manual for that accessory.

PARTS LIST

10 IN. (254 MM) FOLDING COMPOUND MITER SAW PARTS LIST FOR FOLDING COMPOUND MITER SAW - A

I.D. No.	Description	Size	Q'ty	I.D. No.	Description	Size	Q'ty
0831	SHAFT SLEEVE		1	0KDK	CR. RE. PAN HD. SCREW	M5*0.8-16	1
083Z	CORD CLAMP		1	0KMS	HEX. NUT	M6*1.0 T=5	3
0CES	COMPRESSION SPRING		1	0KQW	LOCK NUT	M5*0.8 T=5	1
0CPD	CENTER BOLT		1	0KQX	NUT	M6*1.0 T=6	2
0D87	TORSION SPRING		1	0KR0	NUT	M12*1.75 T=12	1
0D9B	ANCHOR BLOCK		1	0KR3	LOCK NUT	M6*1.0 T=6	1
0DVJ	BLADE WRENCH		1	0KR4	LOCK NUT	M8*1.25 T=8	1
0HG1	COMPRESSION SPRING		1	0KUW	TERMINAL		2
0J4E	FLAT WASHER	φ6*13-1	1	0LYH	DUST GUARD		1
0J4M	FLAT WASHER	φ12*21-1	1	0S1S	COLLAR		1
0J6A	FLAT WASHER	φ8*16-2.5	1	143G	HEX. SOC. TRUSS HD. SCREW	M6*1.0-16	2
0J7F	FLAT WASHER	5/16*7/8-5/64	1	23NX	CORD GUARD		1
0JB0	WAVE WASHER	WW-8	2	271T	FLAT WASHER	φ8*15-1	1
0JE8	C-RING		1	2AH7	COMPRESSION SPRING		1
0JMP	O-RING		1	2FUN	COMPRESSION SPRING		1
0JPE	HEX. HD. BOLT	M6*1.0-20	2	2LWF	CLEVIS PIN		1
0JPF	HEX. HD. BOLT	M6*1.0-25	1	2M0S	LIMIT SWITCH		1
0JUJ	HEX. SOC. HD. CAP BOLT	M6*1.0-12	1	2N7W	BRACING PLATE		1
0JUK	HEX. SOC. HD. CAP BOLT	M6*1.0-16	1	2PDE	LASER WARNING LABEL		1
0JVD	HEX. SOC. HD. CAP BOLT	M5*0.8-35	1	2T9B	ROCKER SWITCH ASS'Y		1
0JZF	HEX. SOC. SET SCREW	M6*1.0-10	3	2VEP	SHAFT		1
0JZN	ARBOR BOLT	M8*1.25-20	1	2YR6	SPRING GUARD		1
0K2L	HEX. SOC. HD. CAP SCREW	M8*1.25-30	4	2ZPA	DUST BAG ASS'Y		1
0K4T	CR. RE. TRUSS HD. SCREW	M5*0.8-20	2	31VX	CR. RE. TRUSS HD. ROUND NECK SCREW	M6*1.0-14	1
0K5D	CR. RE. COUNT HD. SCREW	M6*1.0-20	1	3544	LEAD WIRE ASS'Y		1
0K72	CR. RE. TRUSS HD. SCREW	M5*0.8-12	2	35Q3	HEX. SOC. SET SCREW	M6*1.0-8	1
0K7Z	CR. RE. TRUSS HD. ROUND NECK SCREW	M6*1.0-14	1	36Z9	TENSION PLATE		1
0KB7	CR. RE. PAN HD. TAPPING SCREW	M4*18-16	8	3CK6	CONTROLLER ASS'Y		1
0KD7	CR. RE. PAN HD. SCREW	M4*0.7-10	4	3FVK	LASER COVER		1
0KDH	CR. RE. PAN HD. SCREW	M5*0.8-8	4	3FVL	LASER COVER		1
0KDJ	CR. RE. PAN HD. SCREW	M5*0.8-12	1	3H9M	PIVOT SHAFT		1

**10 IN. (254 MM) FOLDING COMPOUND MITER SAW
PARTS LIST FOR FOLDING COMPOUND MITER SAW - B**

I.D. No.	Description	Size	Q'ty	I.D. No.	Description	Size	Q'ty
3HHM	CR. RE. COUNT HD. SCREW	M4*0.7-8	4	3SPN	MITER HANDLE		1
3HJ0	CR. RE. PAN HD. TAPPING SCREW	M3*24-8	1	3SR0	ANGLE PEGULATOR		1
3LMY	DISC SPRING WASHER	φ12	1	3STM	POWER CABLE		1
3MAY	CR. RE. PAN HD. ROUND NECK SCREW	M6*1.0-9	1	3STZ	HOLD-DOWN CLAMP		1
3NY9	LASER ASS'Y		1	3SVQ	SPECIAL BOLT		1
3NZ6	ARBOR COLLAR		2	3SZY	TRIGGER		1
3PBU	FENCE		1	3TUQ	WARNING LABEL		1
3PC4	ANCHOR PLATE		1	3TUR	CAUTION LABEL		1
3PCH	LOCATION PIN		1	3TUS	WARNING LABEL		1
3QJE	LOCK PIN		2	3TUT	WARNING LABEL		2
3QLP	BUTTON SWITCH		1	3TUU	LASER STICKER		1
3R49	TABLE INSERT		1	3TUV	WARNING LABEL		1
3R7E	BEVEL LOCK HANDLE		1	3TUZ	TILTING SCALE		1
3RJS	TRADEMARK LABEL		1	3TV0	SCALE		1
3S79	MOTOR ASS'Y		1	3TV1	LABEL		1
3S9G	LEVER		1	3TV2	WARNING LABEL		1
3S9H	MOTOR HANDLE (LEFT)		1	3TV3	WARNING LABEL		1
3S9J	MOTOR HANDLE (RIGHT)		1	3U32	POSITIVE STOP LOCKING LEVER		1
3S9K	NEEDLE POINTER		1	3U35	LOWER BLADE GUARD		1
3S9L	TABLE		1	3U3B	ANCHOR BLOCK		1
3S9N	BASE		1	3U4D	SUPPORT BASE		1
3S9P	DETENT BLOCK		1	3U4G	HEX. SOC. HD. CAP SCREW	M6*1.0-30	2
3S9S	SLIDE PLATE		1	3UHA	BLADE		1
3S9Z	CARRYING HANDLE		1	3UGY	INSTRUCTION MANUAL		1
3SA0	CABLE SHIELD		1	3UTW	CAUTION LABEL		1
3SA1	FOLLOWER PLATE		1	3UZ2	WARNING LABEL		1
3SAX	CUTTER SHAFT GUARD		1	3UZN	POWER CABLE ASS'Y		1
3SB9	LEAD WIRE ASS'Y		1	3UZP	MAGIC TAPE		1
3SDU	NEEDLE POINTER		1	3V0X	WARNING LABEL		1
3SPD	CR. RE. TRUSS HD. ROUND NECK SCREW	M6*1.0-20	1	3V6S	WARNING LABEL		1

NOTES

WARRANTY

THREE YEAR LIMITED WARRANTY

PORTER-CABLE will repair, without charge, any defects due to faulty materials or workmanship for three years from the date of purchase. This warranty does not cover part failure due to normal wear or tool abuse. For further detail of warranty coverage and warranty repair information, visit www.portercable.com or call (888) 609-9779. This warranty does not apply to accessories or damage caused where repairs have been made or attempted by others. This warranty gives you specific legal rights and you may have other rights which vary in certain states or provinces.

In addition to the warranty, PORTER-CABLE tools are covered by our:

1 YEAR FREE SERVICE: PORTER-CABLE will maintain the tool and replace worn parts caused by normal use, for free, any time during the first year after purchase.

90 DAYS MONEY BACK GUARANTEE: If you are not completely satisfied with the performance of your PORTER-CABLE Power Tool for any reason, you can return it within 90 days from the date of purchase with a receipt for a full refund – no questions asked.

LATIN AMERICA: This warranty does not apply to products sold in Latin America. For products sold in Latin America, see country specific warranty information contained in the packaging, call the local company or see website for warranty information.

To register your tool for warranty service visit our website at www.portercable.com.

WARNING LABEL REPLACEMENT

If your warning labels become illegible or are missing, call (888) 609-9779 for a free replacement.

The following are PORTER-CABLE trademarks for one or more power tools and accessories: a gray and black color scheme; a “four point star” design; and three contrasting/outlined longitudinal stripes. The following are also trademarks for one or more Porter-Cable and Delta products: 2 BY 4[®], 890[™], Air America[®], AIRBOSS[™], Auto-Set[®], B.O.S.S.[®], Bammer[®], Biesemeyer[®], Builders Saw[®], Charge Air[®], Charge Air Pro[®], CONTRACTOR SUPERDUTY[®], Contractor’s Saw[®], Delta[®], DELTA[®], Delta Industrial[®]. DELTA MACHINERY & DESIGN[™], Delta Shopmaster and Design[®], Delta X5[®], Deltacraft[®], DELTAGRAM[®], Do It. Feel it.[®], DUAL LASERLOC AND DESIGN[®], EASY AIR[®], EASY AIR TO GO[™], ENDURADIAMOND[®], Ex-Cell[®], Front Bevel Lock[®], Get Yours While the Sun Shines[®], Grip to Fit[®], GRIPVAC[™], GTF[®], HICKORY WOODWORKING[®], Homecraft[®], HP FRAMER HIGH PRESSURE[®], IMPACT SERIES[™], Innovation That Works[®], Jet-Lock[®], Job Boss[®], Kickstand[®], LASERLOC[®], LONG-LASTING WORK LIFE[®], MAX FORCE[™], MAX LIFE[®], Micro-Set[®], Midi-Lathe[®], Monsoon[®], MONSTER-CARBIDE[™], Network[®], OLDHAM[®], Omnijig[®], PC EDGE[®], Performance Crew[™], Performance Gear[®], Pocket Cutter[®], Porta-Band[®], Porta-Plane[®], Porter-Cable[®], Porter-Cable Professional Power Tools[®], Powerback[®], POZI-STOP[™], Pressure Wave[®], PRO 4000[®], Proair[®], Quicksand and Design[®], Quickset II[®], QUIET DRIVE TECHNOLOGY[™], QUIET DRIVE TECHNOLOGY AND DESIGN[™], Quick-Change[®], QUIK-TILT[®], RAPID-RELEASE[™], RAZOR[®], Redefining Performance[®], Riptide[®], Safe Guard II[®], Sand Trap and Design[®], Sanding Center[®], Saw Boss[®], Shop Boss[®], Sidekick[®], Site Boss[®], Speed-Bloc[®], Speedmatic[®], Stair Ease[®], Steel Driver Series[®], SUPERDUTY[®], T4 & DESIGN[®], THE AMERICAN WOODSHOP[®], THE PROFESSIONAL EDGE[®], Thin-Line[®], Tiger Saw[®], TIGERCLAW[®], TIGERCLAW AND DESIGN[®], Torq-Buster[®], TRU-MATCH[®], T-Square[®], Twinlaser[®], Unifence[®], Uniguard[®], UNIRIP[®], UNISAW[®], UNITED STATES SAW[®], Veri-Set[®], Versa-Feeder[®], VIPER[®], VT[™], VT RAZOR[™], Water Driver[®], WATER VROOM[®], Waveform[®], Whisper Series[®], X5[®], YOUR ACHIEVEMENT. OUR TOOLS.[®] Trademarks noted with © are registered in the United States Patent and Trademark Office and may also be registered in other countries. Other trademarks may apply.

PORTER-CABLE and the PORTER-CABLE logo are registered trademarks of PORTER-CABLE and are used under license. All rights reserved.

PORTER  CABLE.

Power Tool Specialists, Inc.
684 Huey Road, Rock Hill, SC 29730
(888) 609-9779
www.portercable.com