

GEN1000 i



1,000 MAX WATTS INVERTER GENERATOR

INSTRUCTION MANUAL

READ ALL INSTRUCTIONS AND WARNINGS BEFORE USING THIS PRODUCT.

This manual provides important information on proper operation & maintenance. Every effort has been made to ensure the accuracy of this manual. These instructions are not meant to cover every possible condition and situation that may occur. We reserve the right to change this product at any time without prior notice.

IF THERE IS ANY QUESTION ABOUT A CONDITION BEING SAFE OR UNSAFE,

DO NOT OPERATE THIS PRODUCT!

DO NOT RETURN THIS GENERATOR TO THE RETAILER!

If you experience a problem, have questions or need parts for this product, call Customer Service at 1-866-460-9436, Monday-Friday, 8 AM - 4 PM Central Time. A copy of the sales receipt is required.

FOR CONSUMER USE ONLY – NOT FOR PROFESSIONAL USE.

KEEP THIS MANUAL, SALES RECEIPT & APPLICABLE WARRANTY FOR FUTURE REFERENCE.

CALIFORNIA PROPOSITION 65

WARNING: This product, or the exhaust from this generator, may contain chemicals, including lead, known to the State of California to cause cancer and birth defects or other reproductive harm. Wash hands after handling.

2 YEAR LIMITED EMISSION-RELATED WARRANTY

THIS ENGINE MEETS U.S. EPA EMISSION STANDARDS UNDER 40 CFR 1054.625 .The emission-related limited warranty is valid for two (2) years. Keep the purchase receipt and mail in the product registration card for proof of purchase. Buffalo Corp limits emission-related warranty repairs to authorized service centers for owners located within 100 miles of an authorized service center. For owners located more than 100 miles from an authorized service center, Buffalo Corp will, in its sole discretion, either pay for shipping costs to and from an authorized service center, provide for a service technician to come to the owner to make the warranty repair, or pay for the repair to be made at a local non-authorized service center. The provisions of this paragraph apply only for the contiguous states, excluding the states with high-altitude areas identified in 40 CFR part 1068, Appendix III.

To exercise this warranty, DO NOT RETURN TO RETAILER. Instead, call Customer Service toll free at 1-866-460-9436 (email address info@buffalotools.com) and you will be instructed on where to take the engine for warranty service. Take the generator and proof of purchase (your receipt) to the repair facility recommended by the Customer Service Representative. The warranty does not extend to generators damaged or affected by fuel contamination, accidents, neglect, misuse, unauthorized alterations, use in an application for which the product was not designed and any other modifications or abuse.

1 YEAR LIMITED WARRANTY (30 Day Limited Warranty for Commercial and Rental Purpose)

Generators are warranted to be free from defects in materials and workmanship for a period of 1 YEAR from date of original purchase. Buffalo Corp. is not liable for any indirect, incidental or consequential damages from the sale or use of this product. Any implied warranties are limited to 1 YEAR as stated, or as otherwise stated, in this written limited warranty. Some states do not allow the exclusion or limitation of incidental or consequential damages. Some states do not allow limitation on the length of an implied warranty. Buffalo Corp will repair or replace, at its discretion, any part that is proven to be defective in materials or workmanship under normal use during the 1 YEAR warranty period. Warranty repairs or replacements will be made without charge for parts or labor. Parts replaced during warranty repairs will be considered as part of the original product and will have the same warranty period as the original product. This warranty gives you specific legal rights, and you may have other rights that vary state to state.

Notice Regarding Emissions:

Engines certified to comply with California and U.S. EPA emission regulations for SORE (Small Off Road Equipment) are certified to operate on regular unleaded gasoline and may include the following emission control systems: Three-Way Catalyst (TWC) (if equipped), and Engine Modifications (EM).

Legal Requirements:

Federal and/or State Occupational Safety and Health Administration (OSHA) regulations, local codes, and/or ordinances may apply to the intended use of this generator. Consult a qualified electrician, electrical inspector, and/or the local agency having jurisdiction. Some areas require generators to be registered with local utility companies. Additional regulations may apply if this generator will be used at a construction site.

IMPORTANT SAFETY INSTRUCTIONS

STOP!

Before using this generator and if you have any questions regarding the hazard and safety notices listed in this manual and/or on this generator, call 1-866-460-9436, Monday - Friday, 8 AM - 4 PM Central Time.

DANGER

Carbon Monoxide Gas: When in operation, the exhaust from this generator contains poisonous carbon monoxide gas. Carbon monoxide gas is both odorless and colorless AND may be present even if you do not see or smell gas. Breathing this poison gas can lead to headaches, dizziness, drowsiness, loss of consciousness and eventually death.

- USE THIS GENERATOR ONLY OUTDOORS IN NON-CONFINED AREAS. DO NOT SECURE THE GENERATOR WITH A CHAIN OR ROPE, AS THIS WILL MAKE IT DIFFICULT TO MOVE IN AN EMERGENCY.
- Keep at least several feet of clearance on all sides to allow proper ventilation for this generator.

⚠ WARNING

Chemicals: According to the State of California, the exhaust from this generator contains chemicals known to cause cancer, birth defects, or other reproductive harm.

⚠ WARNING

Flammable Gasoline: This generator may emit highly flammable and explosive gasoline vapors, which can cause severe burns or even death. A nearby open flame can lead to an explosion even if not directly in contact with gasoline.

- Do not operate this generator near open flame.
- Do not smoke near this generator.
- Always operate this generator on a firm, level surface.

Gasoline is highly flammable and explosive. Handling fuel can result in serious injury or burns.

- Always shut down this generator before refueling. Refuel in a well-ventilated area. Keep heat, sparks and flame away while refueling and away from the location where gasoline is stored. Never refuel indoors where gasoline fumes may reach flames and/or sparks.
- Allow this generator to cool for at least 2 minutes before removing the fuel tank cap. Loosen the cap slowly to relieve pressure in the fuel tank. Avoid spilling fuel.
- Do not fill the fuel tank above the upper limit line. Gasoline may expand during operation. Do not fill to the top of the tank.
- Always check for spilled gasoline and immediately wipe it up before starting this generator.
- Empty the fuel tank before storing or transporting this generator.
- Always handle fuel outdoors.
- Before transporting, turn the fuel valve to the “OFF” position and disconnect the spark plug.

NOTE: DO NOT USE GASOLINE CONTAINING MORE THAN 10% ETHANOL (e10)

⚠ WARNING

Usage: Consult a physician(s) before using this generator if using a pacemaker. Electromagnetic fields in close proximity to a heart pacemaker could cause a pacemaker to malfunction or fail. Caution is necessary when near the engine's recoil starter.

⚠ CAUTION

Usage: Prolonged exposure to high noise levels can be hazardous to hearing. Always wear ANSI-approved hearing protection when operating or working around the generator when it is running.

⚠ DANGER

Powerful Voltage: This generator produces powerful voltage, which can result in electrocution.

- ALWAYS ground this generator before using it. (See "Ground the Generator" section in this manual).
- Only electrical devices should be plugged into this generator, either directly or with an extension cord. NEVER connect a building electrical system to this generator without a qualified electrician. *Doing so voids your warranty.* Such connections must isolate generator power from utility power and comply with local electrical laws and codes. Failure to comply can create a back feed into utility lines creating an electrocution hazard, which may result in serious injury or death to utility workers. Such a back feed may cause this generator to explode, burn and create fires when utility power is restored.
- Use a ground fault circuit interrupter (GFCI) in highly conductive areas such as metal decking or steel work. GFCIs are available in-line with some extension cords.
- Do not use this generator in wet conditions (rain, snow, active sprinkler system, wet hands, etc.). Always keep this generator dry and operate it with dry hands.
- Do not allow children or non-qualified persons to operate this generator.

WARNING

GASOLINE IS HIGHLY FLAMMABLE AND EXPLOSIVE. YOU COULD BE BURNED OR SERIOUSLY INJURED IF THE GASOLINE IS IGNITED. Before refueling, stop the engine and keep heat, sparks and flame away. Handle fuel only outdoors. Do not fill the fuel tank above the upper limit line. Wipe up spills immediately.

DANGER

High Temperatures: This generator produces heat when in operation. Temperatures near the exhaust can exceed 150 Degrees Fahrenheit (65 Degrees Celsius).

- Do not touch hot surfaces. Observe all warning placards on this generator denoting hot surfaces.
- Allow this generator to cool for several minutes after use before touching the engine, muffler or other areas that are hot during operation and before storing indoors.
- Hot exhaust may ignite some materials. Keep flammable materials away from this generator.
- Keep at least several feet of clearance on all sides of this generator during operation. Do not enclose this generator in any structure.

WARNING

IMPROPER CONNECTIONS TO A BUILDING CAN ALLOW ELECTRICAL CURRENT TO BACKFEED INTO UTILITY LINES, CREATING AN ELECTROCUTION HAZARD. Connections to a building must isolate generator power from utility power and comply with all applicable laws and electrical codes.

⚠ CAUTION

Usage: Misuse of this generator can damage it or shorten its life.

- Use this generator only for its intended purpose.
- Operate this generator only on a dry, level surface. Do not secure the generator with a chain or rope, which would prevent it from being moved in an emergency.
- Allow this generator to run for several minutes before connecting any electrical devices.
- Promptly turn off any malfunctioning devices and disconnect them.
- Do not operate an excessive number of electrical devices in excess of the wattage capacity of this generator.
- Do not turn on electrical devices until *after* they are connected to this generator.
- Turn off all connected electrical devices before stopping this generator.

⚠ CAUTION

Usage: Prolonged exposure to high noise levels can be hazardous to hearing. Always wear ANSI-approved hearing protection when operating or working around the generator when it is running.

⚠ WARNING

Usage: Avoid the use of extension cords if possible. If you choose to use them, be sure they are sized adequately to handle the flow of electricity. An undersized cord can overheat, short out and cause a fire.

Included with this Generator:

DC connector wires for connecting 12 Volt automotive-type batteries
Spark plug wrench
Screwdriver

 **WARNING**

Usage: Avoid the use of extension cords if possible. If you choose to use them, be sure they are sized adequately to handle the flow of electricity. An undersized cord can overheat, short out and cause a fire.

 **WARNING**

The engine exhaust from this product contains chemicals known to the State of California to cause cancer, birth defects or other reproductive harm.

 **DANGER**

EXHAUST CONTAINS POISONOUS CARBON MONOXIDE GAS THAT CAN BUILD UP TO DANGEROUS LEVELS IN CLOSED AREAS. BREATHING CARBON MONOXIDE CAN CAUSE UNCONSCIOUSNESS OR DEATH. Never run the generator in a closed or even partly closed area where people may be present.

FEATURES:

- 0.55 Gallon Fuel Tank
- 40cc, 4 stroke
- Run Time : 6.3 Hours at 50% load
- 10 ounces Oil
- High Altitude Use: This generator is not recommended for high altitude use above 3,000 feet.
- 1,000 Watts Max/800 W Min AC output
- Low oil shutdown
- Noise Level : 56db at 0% load @23 Ft
- 5,000 RPM
- Recoil Start
- 1.3 HP

DESCRIPTION

- (1) Economy control switch
- (2) Engine switch
- (3) Fuel tank
- (4) Spark plug
- (5) Muffler
- (6) Carrying handle
- (7) Choke lever
- (8) AC pilot light
- (9) Overload indicator light
- (10) Oil warning light
- (11) Ground (earth) terminal
- (12) DC protector
- (13) DC receptacle
- (14) AC receptacle
- (16) Fuel filter
- (17) Fuel tank cap
- (18) Fuel pump
- (19) Recoil starter
- (20) Fuel cock
- (21) Oil filler cap
- (22) Air filter cover

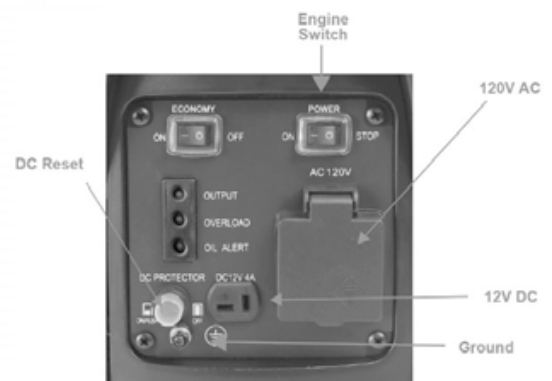
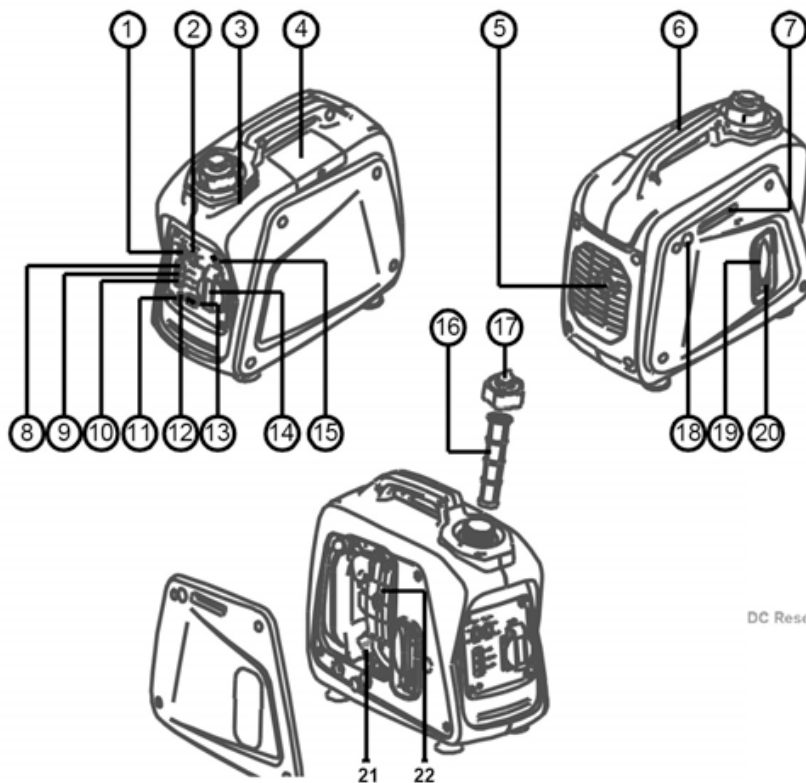

This is a Gasoline Powered Invertor Generator that offers clean power for electronics.

1) ENGINE SWITCH

The engine switch controls the ignition system.

To Start generator, turn POWER switch ON. Then the engine can be started by sliding Choke lever to CHOKE then pull Recoil. Allow engine to run for a few seconds then slide the Choke Lever to OFF.

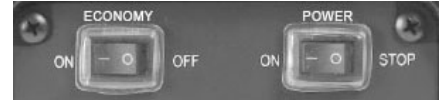

To Stop generator, press ignition circuit to STOP. The engine will not run.

2) ECONOMY CONTROL SWITCH

When the economy control switch is turned “ON”, the economy control unit controls the engine speed according to the connected load. The results are better fuel connection and less noise. (Turn OFF when using less voltage.)

3) LOW OIL ALERT SENSOR

When the oil level falls below the acceptable level, the engine stops automatically. Unless you refill with oil, the engine will not start again.

4) OVERLOAD INDICATOR LIGHT

The overload indicator light comes on when an overload of a connected electrical device is detected, the inverter unit overheats, or the AC output voltage rises. The electronic breaker will then activate, stopping power to the generation in order to protect the generator and any connected electric devices. The output pilot light will flicker GREEN, the overload indicator light will turn RED, & the engine will stop.

- (a) Turn off any connected electric devices and stop the engine
- (b) Reduce the total wattage of connected electric.
- (c) Check for blockages in the cooling air inlet and the control unit & restart engine.
- The generator AC output automatically resets when the engine is stopped and then restarted. The overload indicator light may come on for a few seconds at

first when using electric devices that require a large starting current, such as a compressor or a submergible pump. However, this is not a malfunction.

5) DC CIRCUIT PROTECTOR

The DC circuit protector turns off automatically when the load exceeds the generator rated output. Reduce the load to within specified generator rated output if the DC circuit protector turns off.

6) FUEL COCK

The fuel cock is used to supply fuel from the tank to the carburetor.

Turn ON when getting ready to start the generator. Turn OFF when finished using the generator.



CHECK ENGINE FUEL

- Make sure there is sufficient fuel in the tank.
- If fuel is low, refill with unleaded automotive gasoline.
- Be sure to use the fuel filter screen on the fuel filter neck.
- Recommended fuel: Unleaded gasoline.
- Fuel tank capacity: 0.5 Gallon
- Do not refill tank while engine is running or hot.
- Close fuel cock before refueling with fuel.
- Be careful not to admit dust, dirt, water or other foreign objects into fuel.
- Do not fill above the top of the fuel filter or it may overflow when the fuel heats up later and expands.
- Keep open flames away.

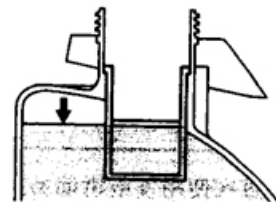

CHECK ENGINE OIL

Remove side panel, then remove oil filler cap and check the engine oil level. Make sure the engine oil is at the upper level of the oil filler hole. Add oil as necessary.

- **WARNING:** The generator has been shipped without engine oil. Fill with oil or it will not start.
- Do not tilt the generator when adding engine oil. This could result in overfilling and damage to the engine
- If oil level is below the lower level line, refill with suitable oil to upper level line. Do not screw in the oil filler cap when checking oil level.
- Oil SAE 10W30 Oil capacity: 10 oz.

GROUND

Make sure to ground the generator.

OPERATION

STARTING THE ENGINE

- Before starting the engine, do not connect electric apparatus.

1. Turn the fuel cock lever to the “**ON**” position.
2. Turn the fuel tank cap air vent knob clockwise to the “**OPEN**” position. Turn the engine switch to the “**ON**” or “**RUN**” position.
3. Turn the choke lever to the "Close/Choke" position.
4. PUMP the PRIMER button until the glass bowl is full.
5. Pull the recoil starter handle slowly until resistance is felt. This is the “Compression” point. Return the handle to its original position and pull swiftly. Do not fully pull out the rope. After starting, allow the starter handle to return to its original position while still holding the handle. Grasp the carrying handle firmly to prevent the generator from falling over when pulling the recoil starter.
6. Warm up the engine without a load for a few minutes.

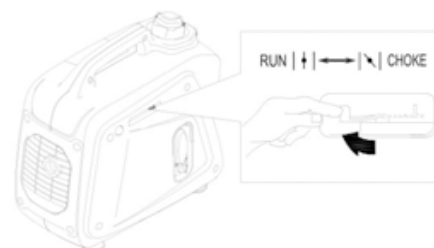
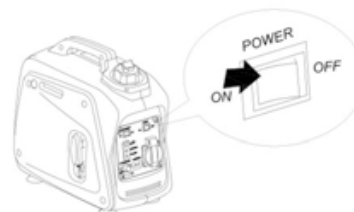
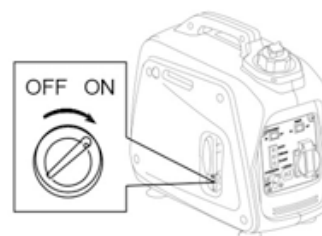

7. Turn the choke lever back to RUN position then plug in appliances.

USING ELECTRIC POWER

AC APPLICATION

- (a) Turn off the switch(es) of the electrical appliance(s) before connecting to the generator.
- (b) Insert the plug(s) of the electrical appliance(s) into the receptacle.
 - Be sure the electric apparatus is turned off before plugging in.
 - Be sure the total load is within generator rated output.
 - Be sure the socket load current is within socket rated current.
 - The economy control switch must be turned to “**OFF**” when using electric devices that require a large starting current, such as a compressor or a submergible pump.

DC APPLICATION

This usage is applicable to 12V battery charging.

Be sure the economy control switch is turned off while charging the battery.

STOPPING THE ENGINE

1. Turn off the power switch of the electric apparatus or disconnect any electric devices.
2. Turn the engine switch to “**STOP**” position.
3. Turn the fuel cock lever to “**OFF**”.

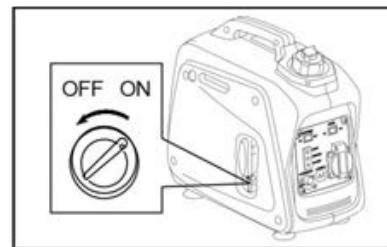

Turn the fuel tank cap air vent knob counterclockwise to the “**CLOSED**” position

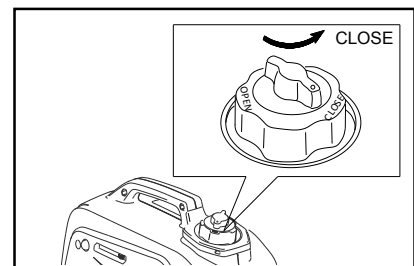

PERIODIC MAINTENANCE

MAINTENANCE CHART

Regular maintenance is most important for the best performance and safe operation.

| Item | Remarks | Pre-operation check (daily) | Initial 1 months or 20 Hr | Every 3 months or 50 Hr | Every 6 months or 100 Hr | Every 12 months or 300 Hr |
|-----------------|--|-----------------------------------|---------------------------------|-------------------------------|--------------------------------|---------------------------------|
| Spark Plug | Check condition adjust gap and clean. Replace if necessary. | | | ● | | |
| Engine Oil | Check oil level | ● | | | | |
| | Replace | | ● | | ● | |
| Oil filter | Clean oil filter | | | | ● | |
| Air Filter | Clean. Replace if necessary. | | | ● | | |
| Fuel Filter | Clean fuel cock filter. Replace if necessary | | | | ● | |
| Choke | Check choke operation | ● | | | | |
| Valve Clearance | Check and adjust when engine is cold. | | | | | ● |
| Fuel Line | Check fuel hose for crack or damage. Replace if necessary. | ● | | | | |
| Exhaust System | Check for leakage. Retighten or replace gasket if necessary | ● | | | | |
| | Check muffler screen. Clean / replace if necessary. | | | | | ● |

| | | | | | | |
|------------------------|--|---|--|--|---|---|
| Carburetor | Check choke operation | ● | | | | |
| Cooling system | Check fan damage. | | | | | ● |
| Starting system | Check recoil starter operation. | ● | | | | |
| Idle speed | Check and adjust engine idle speed | | | | | ● |
| Fittings/ Fasteners | Check all fittings and fasteners correct if necessary. | | | | ● | |
| Crankcase breather | Check breather hose for cracks or damage. Replace if necessary | | | | | ● |
| Generator | Check the pilot light comes on | ● | | | | |

ENGINE OIL REPLACEMENT

1. Place the machine on a level surface and warm up the engine for several minutes. Then stop the engine and turn the fuel cock knob to “**OFF**”. Turn the fuel tank cap air vent knob clockwise.

2. Loosen the screw and remove the cover.

3. Remove the oil filler cap

4. Place an oil pan under the engine.
Tilt the generator to drain the oil completely

5. Replace the generator on a level surface.

6. Add engine oil to the upper level.

7. Install the oil filler cap

8. Install the cover and tighten the screw

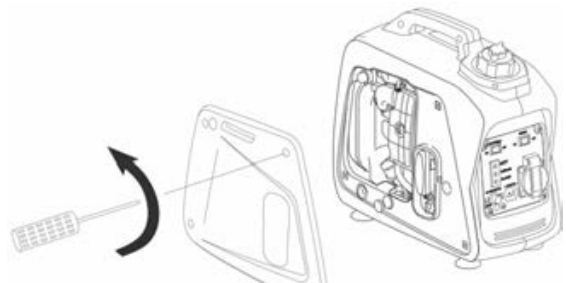
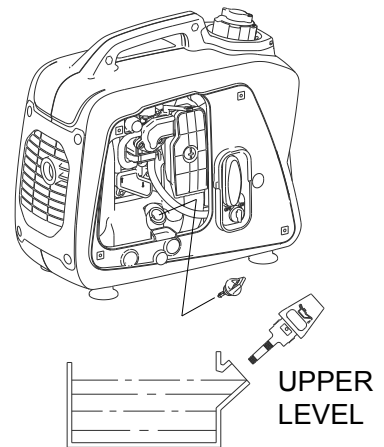

- Engine Oil SAE 10W30 Capacity: 10 oz.
- Be sure no foreign material enters the crankcase.
- Do not tilt the generator when adding engine oil. This could result in overfilling and damage to the engine
- Clean the oil filter every other 100 hr.

WASHABLE AIR FILTER

Maintaining an air cleaner in proper condition is very important. Dirt induced through improperly installed, improperly serviced, or inadequate elements damages and wears out engines. Keep the element always clean.

1. Remove the cover.
2. Remove the air filter cover and element.
3. Wash the element in solvent and dry.
4. Oil the element and squeeze out excess oil. The element should be wet but not dripping.
5. Insert the element into the air filter.
6. Install the cover.

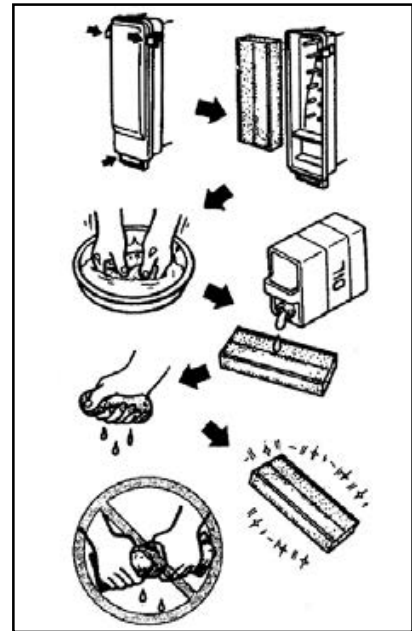

The engine should never run without the Filter; excessive piston and/or cylinder wear may result.

CLEANING AND ADJUSTING SPARK PLUG

1. Remove the cover.
2. Check for discoloration and remove the carbon.
3. Check the spark plug type and gap.

Standard Spark Plug: CMR6A

Spark Plug Gap: 0.6-0.7 mm (0.024-0.028 in)

4. Install the spark plug.
5. Install the cover

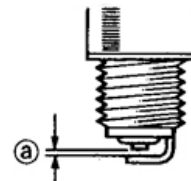

FUEL TANK FILTER

1. Remove the fuel tank cap and filter.
 2. Clean the filter with solvent. If damaged, replace.
 3. Wipe the filter and insert it.
- Be sure the tank cap is tightened securely.

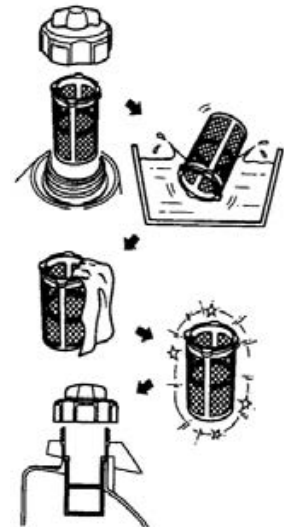

MUFFLER SCREEN

- The engine and muffler will be very hot after the engine has been run.
- Avoid touching the engine and muffler while they are still hot with any part of your body or clothing during inspection or repair.

1. Remove the cover.
2. Remove the muffler screen.
3. Use the flathead screw driver to pry the spark arrester out from the muffler
4. Remove the carbon deposits on the muffler screen and spark arrester using a wire brush.
5. Install the muffler screen.
6. Install the cover

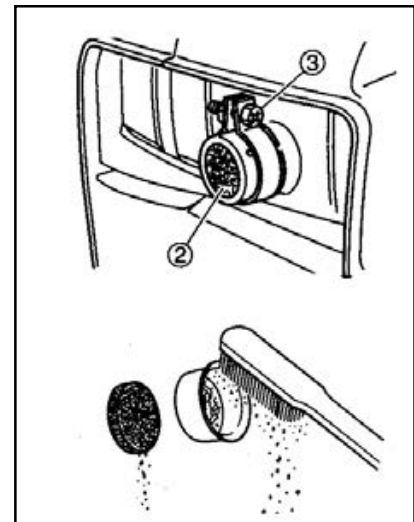
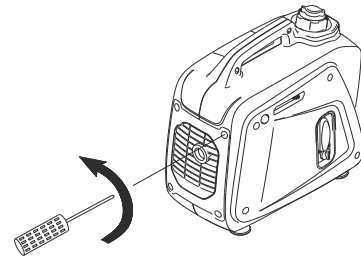

TROUBLE SHOOTING

Engine won't start

1. Fuel systems

No fuel supplied to combustion chamber.

- No fuel in tank....Supply fuel.

- Fuel in tank....Fuel tank cap air vent knob to “**OPEN**”, fuel cock knob to “**OPEN**”.
- Clogged fuel line....Clean fuel line.
- Clogged carburetor....Clean carburetor.

Engine oil system

Insufficient

- Oil level is low....Add engine oil.

Electrical systems

Poor spark

- Spark plug dirty with carbon or wet....Remove carbon or wipe spark plug dry.
- Faulty ignition system....Consult dealer.

Compression insufficient

- Worn out piston and cylinder....Consult dealer.

Generator won't produce power

Safety device (AC) to “OFF” ...Stop the engine, then restart.

Safety device (DC) to “OFF” ...Press to reset the DC protector

STORAGE

Long term storage of your machine will require some preventive procedures to guard against deterioration.

1) DRAIN THE FUEL

1. Remove the fuel tank cap, drain the fuel from the fuel tank
2. Remove the cover, drain fuel from the carburetor by loosening the drain screw.

2) ENGINE

1. Remove the spark plug, pour in about one tablespoon of SAE 10W30 motor oil into the spark plug hole and reinstall the spark plug.
2. Use the recoil starter to turn the engine over several times (with ignition off).
3. Pull the recoil starter until you feel compression.
4. Stop pulling.
5. Clean exterior of the generator and apply a rust inhibitor.
6. Store the generator in a dry, well-ventilated place, with the cover place over it.
7. The generator must remain in a vertical position.

SPECIFICATION

| MODEL | | GEN1000i | |
|------------------|-------------------|---|------|
| GENERATOR | Type | Invertor Generator | |
| | AC Voltage | | |
| | | 60Hz | 120V |
| | Max. Output | 1.00 kVA | |
| | Rated Output | 0.80 kVA | |
| | Power Factor | 1.0 | |
| | DC Output | 12V/4.0A | |
| ENGINE | Model | XY139F-6 | |
| | Type | Air-cooled, 4 cycle, OHV, Gasoline Engine | |
| | Bore×Stroke mm×mm | 39×33.5 | |

| | | | |
|------------------|----------------------------|-----------------------------|--|
| | Displacement | 40 cc | |
| | Max. Output | 0.9KW/5500rpm | |
| | Fuel | Regular Automobile Gasoline | |
| | Fuel tank Capacity | 0.55 Gallon | |
| | Rated Continuous Operation | 6.3 hr @ 50% load | |
| | Lubricating oil | SAE 10W30 | |
| | Lubricating oil Capacity | 10 ounce | |
| | Starting System | Recoil Starter | |
| | Ignition system | C.D.I. | |
| | Spark Plug: Type | CMR6A (TORCH) | |
| DIMENSION | Net dimension L×W×H | 395×209×355 | |
| | Overall dimension L×W×H | 425×230×380 | |
| | Net Weight | 9.2 Kg | |
| | Gross Weight | 11.4Kg | |

- Specifications subject to change without prior notice.

- High Altitude Use: This generator is not recommended for high altitude use above 3,000 feet.

STORAGE INSTRUCTIONS

Long term storage of your machine will require some preventive procedures to guard against deterioration.

1. DRAIN THE FUEL

Remove the fuel tank cap, drain the fuel from the fuel tank

Remove the cover, drain fuel from the carburetor by loosening the drain screw.

2. ENGINE

Remove the spark plug, pour in about one tablespoon of SAE 10W30 motor oil into the spark plug hole and reinstall the spark plug.

Use the recoil starter to turn the engine over several times (with ignition off).

Pull the recoil starter until you feel compression.

Stop pulling.

Clean exterior of the generator and apply a rust inhibitor.

Store the generator in a dry, well-ventilated place, with the cover place over it.

The generator must remain in a vertical position

WIRING DIAGRAM

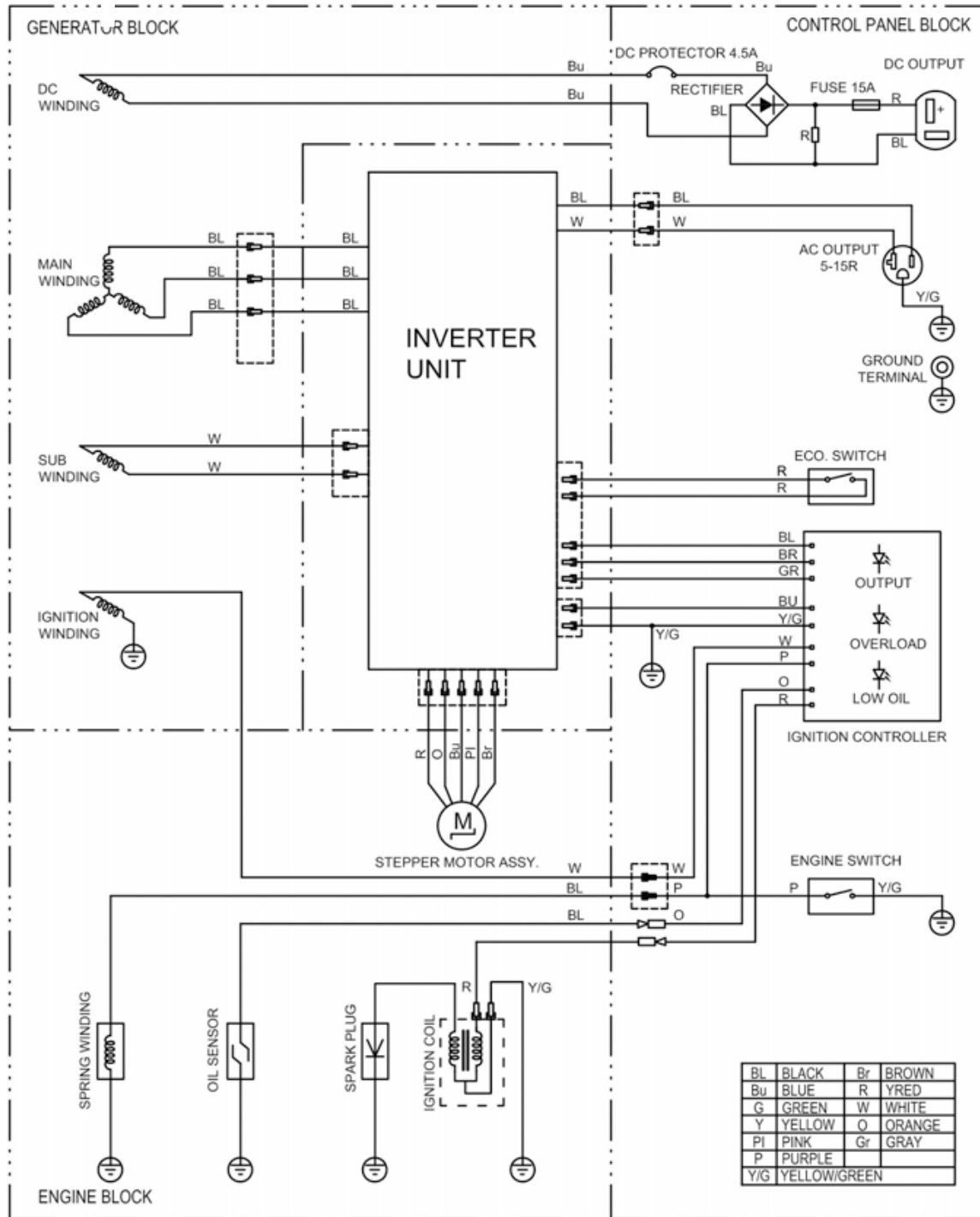

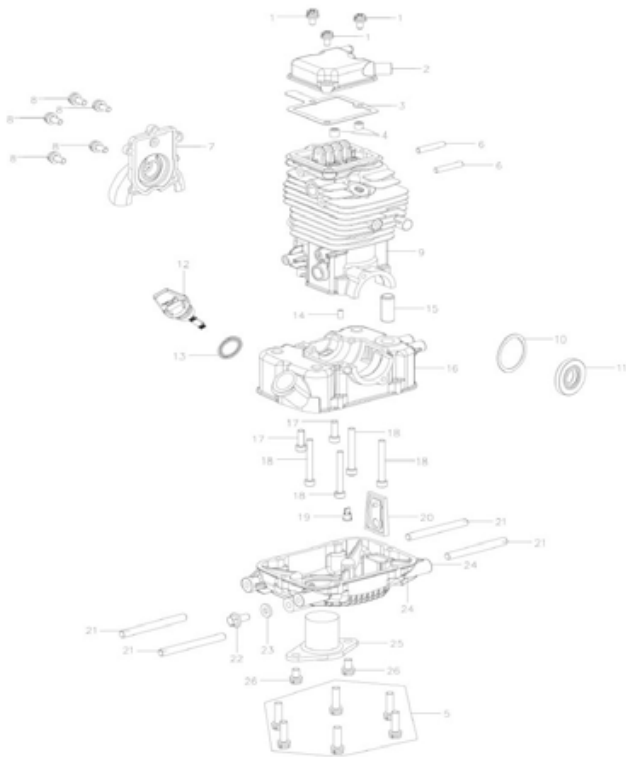

FIG.A CRANKCASE ASSY

| No. | Part No. | Description | Qty |
|-----|----------------|---------------------------|-----|
| 1 | 00252000502011 | Screw M5×20 | 3 |
| 2 | 14760100001001 | Cylinder Head Cover | 1 |
| 3 | 14760100002011 | Cylinder Head Cover Seal | 1 |
| 4 | 14760101001001 | Valve Oil Seal | 2 |
| 5 | 00252000502511 | Dual-Head Bolts M5×70 | 6 |
| 6 | 14760100005041 | Dual-Head Bolts M5×28 | 2 |
| 7 | 14760100003001 | Cam Chamber Cover | 1 |
| 8 | 00252000501411 | Screw M5×14 | 5 |
| 9 | 14810101000101 | Upper Crankcase | 1 |
| 10 | 14770100004041 | Washer 30×37×1 | 1 |
| 11 | 14760100007102 | Oil Seal 15×35×5 | 1 |
| 12 | 14760102101003 | Oil Gauge | 1 |
| 13 | 14760102102101 | Oil Gauge Gasket | 1 |
| 14 | 00510000400801 | Dowel Pin 4×8 | 1 |
| 15 | 14760102003001 | Ventilation Nozzle | 1 |
| 16 | 14760102001001 | Lower Crankcase | 1 |
| 17 | 00204000501641 | Screw M5×16 | 2 |
| 18 | 00204000504041 | Screw M5×40 | 4 |
| 19 | 14760102002101 | Rubber One-Way Valve | 1 |
| 20 | 14760501000001 | One-Way Valve Components | 1 |
| 21 | 14760103003011 | Dual-Head Bolts M6×36 | 4 |
| 22 | 00031000601212 | Hexagon Flange Bolt M6×12 | 1 |
| 23 | 14760103002031 | Aluminium Gasket 6×13×2 | 1 |
| 24 | 14760103001001 | Oil Pan | 1 |
| 25 | 14620103100002 | Oil Level Sensor | 1 |
| 26 | 00252000601811 | Screw M6×18 | 2 |

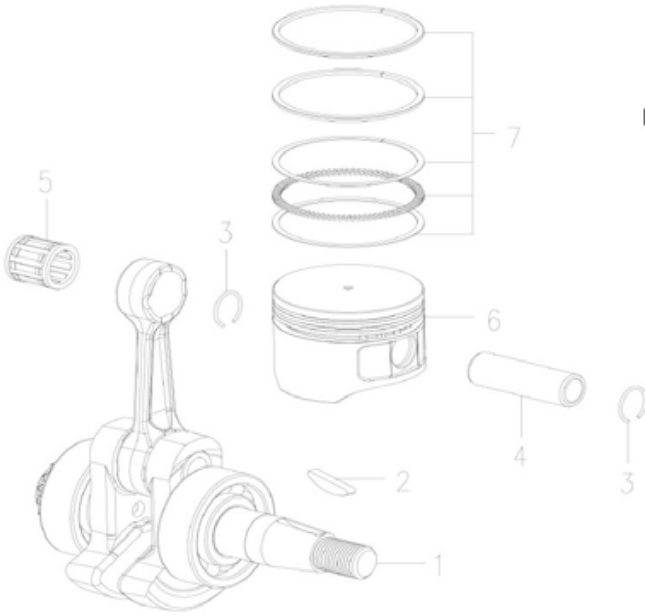

FIG B. CRANKSHAFT PISTON

| No. | Part No. | Description | Qty |
|-----|----------------|------------------------|-----|
| 1 | 14760302000001 | Connecting Rod | 1 |
| 2 | 11310300010001 | Woodruff Key | 1 |
| 3 | 14760300001002 | Piston Pin Clip | 2 |
| 4 | 14760300002002 | Piston Pin | 1 |
| 5 | 00833710141402 | Needle Bearing K101414 | 1 |
| 6 | 14810301001001 | Piston | 1 |
| 7 | 14780301006001 | Piston Ring | 1 |

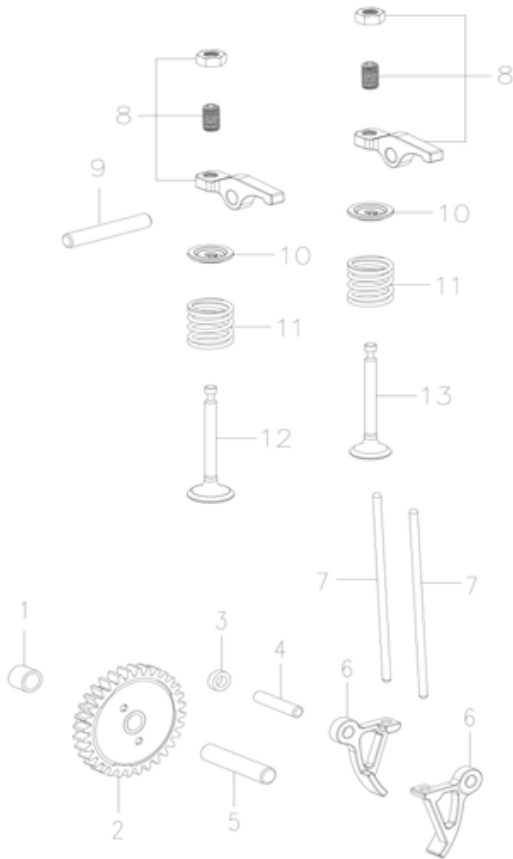

FIG C. CAMSHAFT

| No. | Part No. | Description | Qty |
|-----|----------------|--------------------------|-----|
| 1 | 14760100006001 | Dowel Bush | 1 |
| 2 | 14760401100012 | Camshaft | 1 |
| | 14760401001002 | Decompression of the pin | 1 |
| | 14760401002102 | Torsional spring | 1 |
| | 14760401003002 | Cover for cam | 1 |
| 3 | 14760400010041 | Rocker Gasket | 1 |
| 4 | 00504000402003 | Pin4 g4×20 | 1 |
| 5 | 00504000603003 | Pin4 g6×30 | 1 |
| 6 | 14760400006002 | Lower Rocker | 2 |
| 7 | 14760400009002 | Tappet | 2 |
| 8 | 14760400005002 | Upper Rocker | 2 |
| 9 | 00504000503203 | Pin 5 g6×32 | 1 |
| 10 | 14760400003002 | Valve Spring Seat | 2 |
| 11 | 14760400004002 | Valve Spring | 2 |
| 12 | 14760400001003 | Intake Valve | 1 |
| 13 | 14760400002003 | Exhaust Valve | 1 |

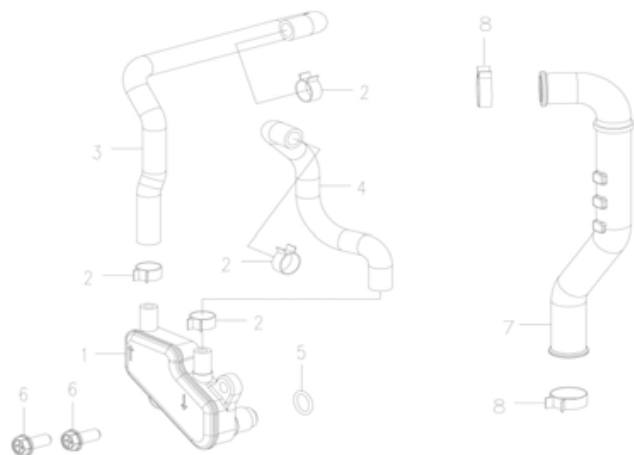

FIG D. LUBRICATION SYSTEM

| No. | Part No. | Description | Qty |
|-----|----------------|---------------------------|-----|
| 1 | 14760502000101 | Deaerator | 1 |
| 2 | 14760500005001 | Pipe Hoop 9 | 4 |
| 3 | 14610500002001 | Respiratory Tube | 1 |
| 4 | 14610500003001 | Outlet Tube | 1 |
| 5 | 14760500004003 | O Ring | 1 |
| 6 | 00031000501612 | Hexagon Flange Bolt M5×16 | 2 |
| 7 | 14610500001001 | Upper Oil Pipe | 1 |
| 8 | 11311600006002 | Pipe Hoop 13 | 2 |

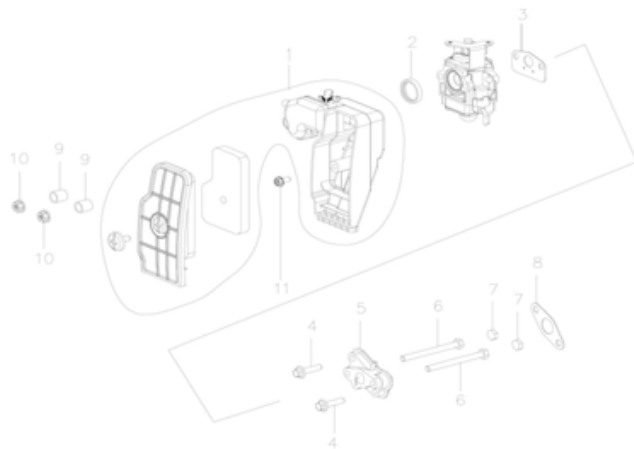

FIG E. AIR CLEANER

| No. | Part No. | Description | Qty |
|-----|----------------|------------------------------|-----|
| 1 | 14760801000002 | Air Filter | 1 |
| | 14760801003002 | Foam | 1 |
| | 14760801007021 | big head chrome plated Screw | 1 |
| 2 | 14760800004001 | Gasket of Air Filter | 1 |
| 3 | 14780800003002 | Gasket of Carburator | 1 |
| 4 | 00033000502211 | Hexagon Flange Bolts M5×22 | 2 |
| 5 | 14810800002001 | Insulation Board Components | 1 |
| 6 | 00026000505551 | Hexagon Flange Bolts M5×55 | 2 |
| 7 | 14810800003001 | Block rubber | 2 |
| 8 | 14810800001012 | Insulation Board Gasket | 1 |
| 9 | 15561100004002 | Fan Volute Bush | 2 |
| 10 | 00129000500011 | Hexagon Flange Bolts M5 | 2 |
| 11 | 00427014801641 | Tap Screw ST4.8×16-F.H | 1 |

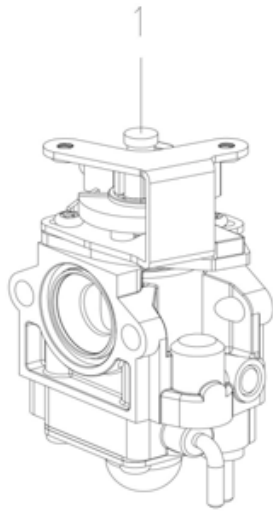

FIG.F CARBURETOR

| No. | Part No. | Description | Qty |
|-----|----------------|-------------|-----|
| 1 | 14760901000001 | Carburator | 1 |

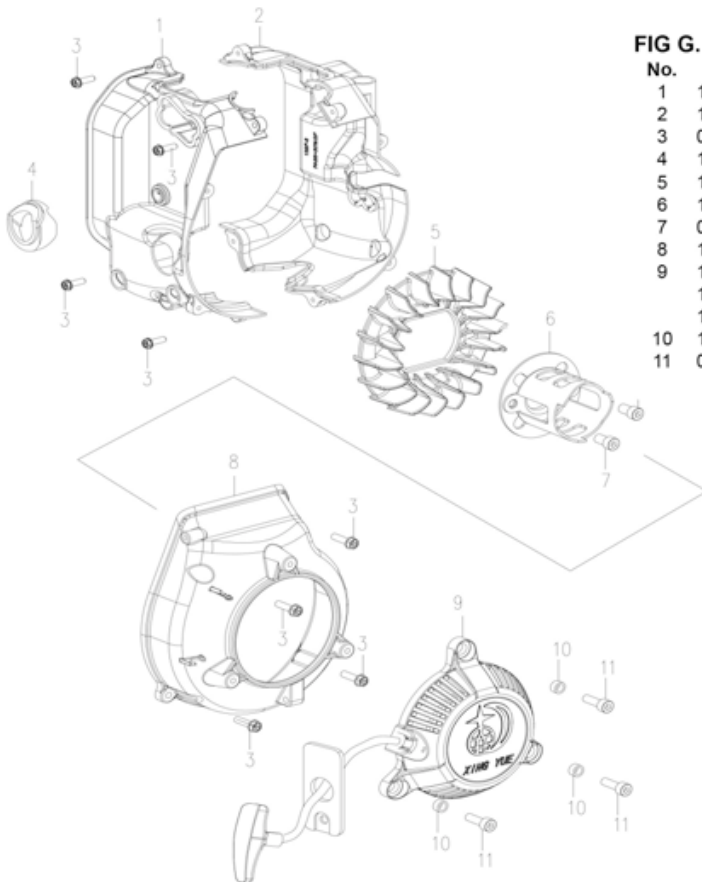

FIG G. RECOIL STARTER

| No. | Part No. | Description | Qty |
|-----|----------------|------------------------------|-----|
| 1 | 14811100001001 | Air Guide Sleeve A | 1 |
| 2 | 14761100014001 | Air Guide Sleeve B | 1 |
| 3 | 00427014801641 | Tap Screw ST4.8×16 | 8 |
| 4 | 14611100006002 | Oil Filler Hole Airproof Pad | 1 |
| 5 | 14761100001002 | Cooling Fan | 1 |
| 6 | 14760602000001 | Starting Hub | 1 |
| 7 | 00204000601041 | Inner Hexagon Screw M6×10 | 2 |
| 8 | 14761100002002 | Fan Volute | 1 |
| 9 | 14760601000002 | Recoil Starter | 1 |
| | 15560602001101 | Handle | 1 |
| | 15560602003001 | Fender | 1 |
| 10 | 15600600002003 | Recoil Starter Bush | 3 |
| 11 | 00031000501611 | Hexagon Flange Bolts M5×16 | 3 |

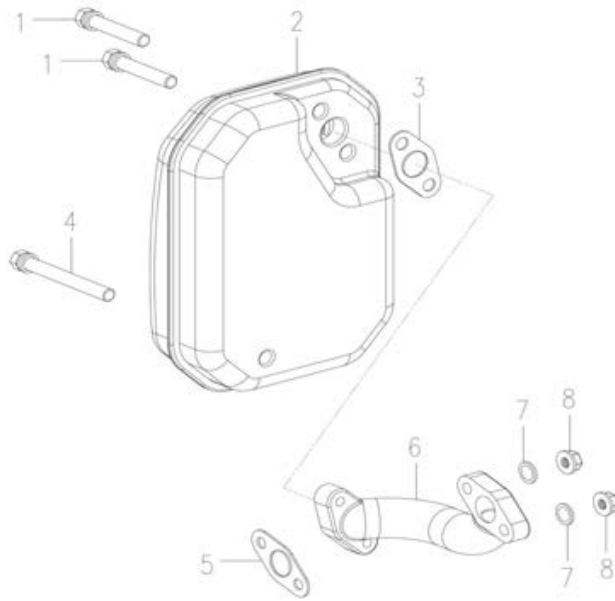

FIG H. MUFFLER

| No. | Part No. | Description | Qty |
|-----|----------------|-----------------------|-----|
| 1 | 00722000603511 | Bolt M6×35 | 2 |
| 2 | 14760701000001 | Muffler | 1 |
| 3 | 14760700001011 | Muffler Pipe Gasket | 1 |
| 4 | 00722000605511 | Bolt M6×55 | 1 |
| 5 | 14760700003011 | Muffler Gasket | 1 |
| 6 | 14760700002003 | Muffler Pipe | 1 |
| 7 | 00030000500041 | Washer 5 | 2 |
| 8 | 00101000500011 | Hexagon Flange Nut M5 | 2 |

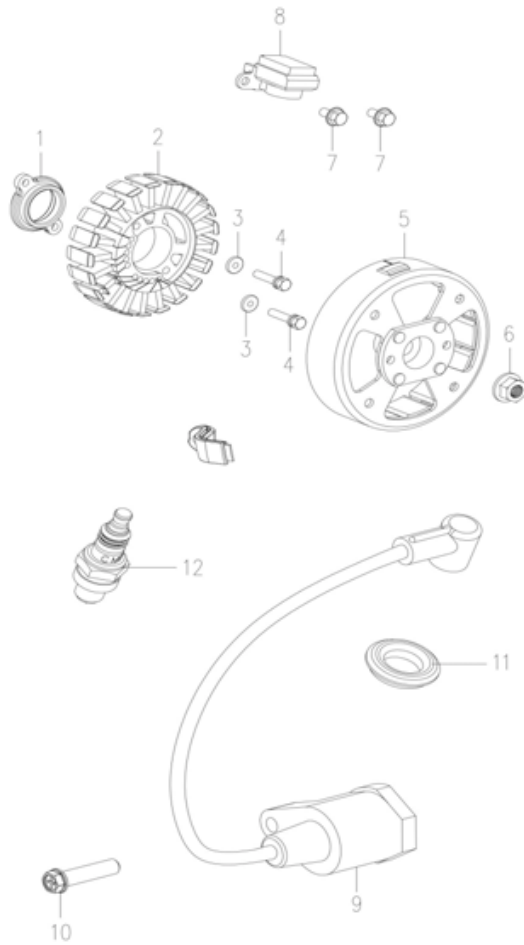

FIG I. GENERATOR

| No. | Part No. | Description | Qty |
|-----|----------------|-----------------------------|-----|
| 1 | 1476100001001 | Locating Plate | 1 |
| 2 | 14761001101101 | Stator 0.8KW 230V 580Hz | 1 |
| | 1476100002002 | Bushing | 1 |
| 3 | 00030000500041 | Washer 5 | 1 |
| 4 | 00033000502211 | Hexagon Flange Bolts M5x35 | 2 |
| 5 | 14761001200101 | Rotor | 1 |
| 6 | 00129001000032 | Hexagon Flange Nut M10x1.25 | 1 |
| 7 | 00033000501001 | Hexagon Flange Bolts M5x10 | 2 |
| 8 | 14761000004002 | Trigger | 1 |
| 9 | 14761003000101 | Ignition Coil | 1 |
| 10 | 00241004802541 | Tap Screw ST4.8x25-F.H | 1 |
| 11 | 14761000003001 | Ignition Coil Cap Seal | 1 |
| 12 | 14761002000001 | Spark Plug CMR6A | 1 |

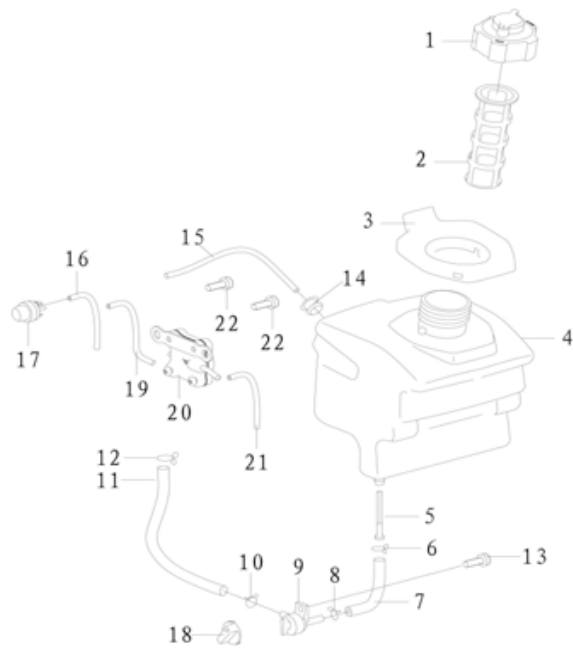
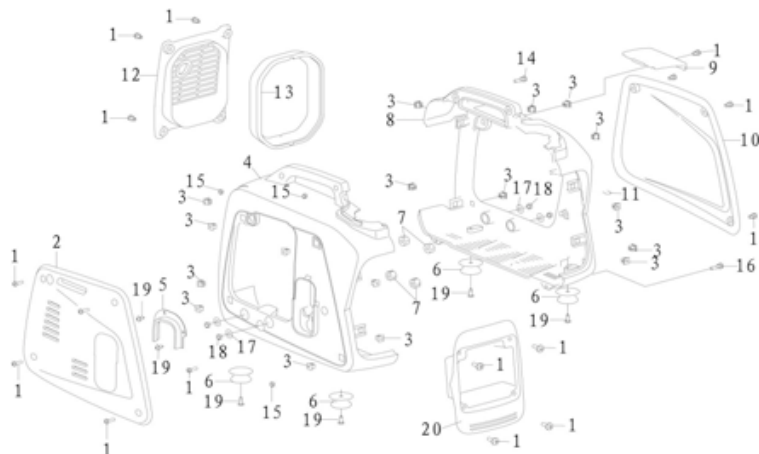

FIG J. FUEL TANK(EPA)

| No. | Part No. | Description | Qty |
|-----|--------------|-----------------------------|-----|
| 1 | 462405010000 | Fuel Tank Cap Assy. | 1 |
| 2 | 462405020000 | Fuel Tank Filter | 1 |
| 3 | 460703000080 | Fuel Tank Port Rubber | 1 |
| 4 | 460705010011 | Fuel Tank (EPA) | 1 |
| 5 | 462405030000 | Fuel Outlet Filter | 1 |
| 6 | 480202020110 | Steel Wire Clamp ø11 | 1 |
| 7 | 460705000011 | Fuel Hose(EPA) | 1 |
| 8 | 480202020100 | Steel Wire Clamp ø10 | 1 |
| 9 | 460705020000 | Fuel Cock | 1 |
| 10 | 480202010090 | Steel Wire Clamp ø9 | 1 |
| 11 | 460705000021 | Fuel Hose 4.5×7.5×180(EPA) | 1 |
| 12 | 480202010080 | Steel Wire Clamp ø8 | 1 |
| 13 | 004210148013 | Tap Screw GB/T845 ST4.8×13- | 1 |
| 14 | 460705010020 | Fuel-hole Plug | 1 |
| 15 | 480201250511 | Fuel Hose 2.5×5×120(EPA) | 1 |
| 16 | 480201250511 | Fuel Hose 2.5×5×80(EPA) | 1 |
| 17 | 460705040000 | Fuel Lubricator | 1 |
| 18 | 460705010040 | Fuel Cock Knob | 1 |
| 19 | 480201250511 | Fuel Hose 2.5×5×95(EPA) | 1 |
| 20 | 460705050000 | negative pressure pump | 1 |
| 21 | 480201250511 | Fuel Hose 2.5×5×110(EPA) | 1 |
| 22 | 004210348095 | Tap Screw GB/T845 ST4.8×9.5 | 2 |

FIG K. SHELL

| No. | Part No. | Description | Qty |
|-----|--------------|-------------------------------|-----|
| 1 | 004210148013 | Screw 4.8×13-F | 18 |
| 2 | 460703000050 | Right Side Cover | 1 |
| 3 | 460703000110 | Fastener | 17 |
| 4 | 460703000040 | Right Cover of Shell | 1 |
| 5 | 460703000061 | Edge Protection | 1 |
| 6 | 460703000140 | Vibration Absorber | 4 |
| 7 | 460703000120 | Rubber Pad Φ6×Φ16×10 | 4 |
| 8 | 460703000010 | Left Cover of Shell | 1 |
| 9 | 460703000030 | Upper Cover | 1 |
| 10 | 460703000020 | Left Side Cover | 1 |
| 11 | 461503000080 | Clamp | 1 |
| 12 | 460703000090 | Muffler Cover | 1 |
| 13 | 460703000100 | Muffler Cover Seal | 1 |
| 14 | 007090005018 | Screw GB/T9074.4 M5×18 | 2 |
| 15 | 001200005001 | Hexagon Nut M5 | 4 |
| 16 | 002260005016 | Cross Pan Head Screw M5×16 | 2 |
| 17 | 460703000130 | Rubber Pad Φ6.5×Φ16×2 | 4 |
| 18 | 001410006001 | Lock Nut GB/T6187 M6 | 4 |
| 19 | 004210348095 | Tap Screw GB/T845 ST4.8×9.5-F | 6 |
| 20 | 460703000070 | Panel Box | 1 |



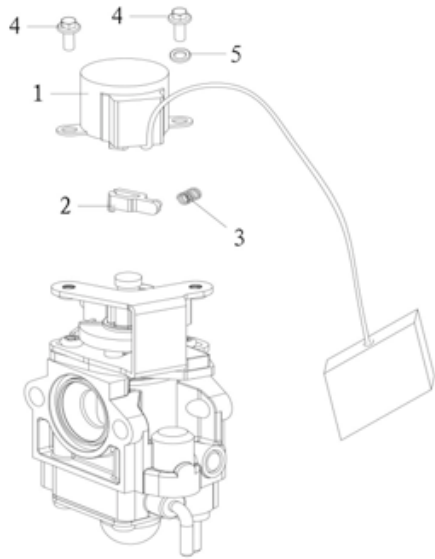

FIG L. GOVERNOR

| No. | Part No. | Description | Qty |
|-----|--------------|------------------|-----|
| 1 | 460720020000 | Stepper Motor | 1 |
| 2 | 155609000020 | Drive Arm | 1 |
| 3 | 155609000010 | Drive Arm Spring | 1 |
| 4 | 007080004006 | Screw M4×6 | 2 |
| 5 | 003000004001 | Spring Washer 4 | 1 |

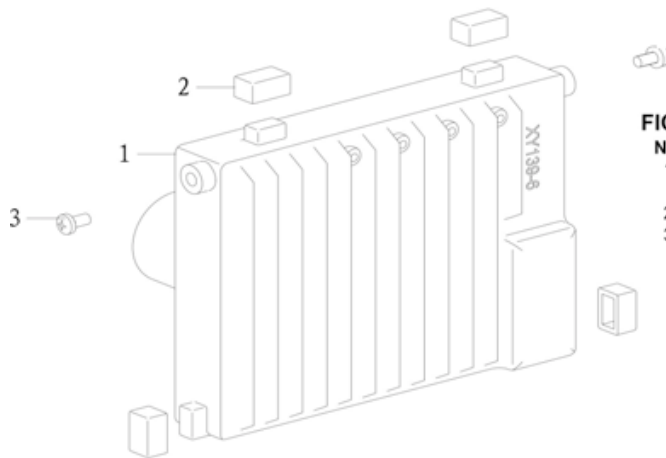

FIG M. INVERTER

| No. | Part No. | Description | Qty |
|-----|--------------|-----------------------------|-----|
| 1 | 460719010000 | Inverter 0.7Kw 120V~60Hz | 1 |
| | 460719010000 | Inverter 0.7Kw 100V~50/60Hz | 1 |
| 2 | 460719000010 | Inverter Gasket | 4 |
| 3 | 007090005012 | Screw GB/T9074.4 M5×12 | 2 |

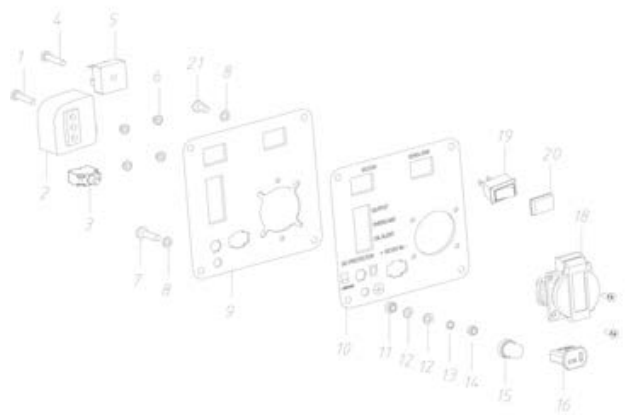

FIG N. CONTROL PANEL (FOR USA)

| No. | Part No. | Description | Qty |
|-----|--------------|--------------------------------|-----|
| 1 | 007090005016 | Cross Pan Head Screw M5×16 | 1 |
| 2 | 462417016000 | Ignition Control Module | 1 |
| 3 | 480107881450 | Overload Protector 4.5A | 1 |
| 4 | 007080005016 | Cross Pan Head Screw M5×16 | 1 |
| 5 | 480110350200 | Rectifier KBPC3502 | 1 |
| 6 | 001280004001 | Hexagon Flange Nut M4 | 4 |
| 7 | 000330005016 | Flange Bolt GB/16674 M5×16 | 1 |
| 8 | 003210005001 | Lock Gasket GB862.2 φ5 | 3 |
| 9 | 460717011000 | Panel Components | 1 |
| 10 | 460788000030 | Panel Sticker | 1 |
| 11 | 001280005001 | Flange Nut GB/T6177 M5 | 1 |
| 12 | 003020005001 | Flat Washer GB/T97 φ5 | 2 |
| 13 | 003000005001 | Spring Washer GB/T93 φ5 | 1 |
| 14 | 001200005001 | Hexagon Nut GB/T6170 M5 | 1 |
| 15 | 480107000020 | Water-Proof Cap of Protector | 1 |
| 16 | 480101090030 | DC Charging Socket | 1 |
| 17 | 002210004012 | Countersunk Head Screw M4×12 | 4 |
| 18 | 480101020040 | American Socket 5-15R | 1 |
| 19 | 480105010010 | Boat Switch | 2 |
| 20 | 480105090010 | Water-Proof Cap of Boat Switch | 2 |
| 21 | 007090005008 | Screw M5×8 | 2 |
| | 460717010000 | Control panel | 1 |

201701